

RESEARCH ARTICLE | JUNE 17 2025

Determination of optimum geometrical parameters of the working bodies of cotton processing machines and mechanisms

Soyibjon Negmatov; Nodira Abed; Olim Eshkobilov ; Shokhista Karshiyeva

AIP Conf. Proc. 3286, 060012 (2025)

<https://doi.org/10.1063/5.0281773>



Articles You May Be Interested In

Research of internal stresses of polymer and paint coatings by console and force methods formed by amine and isocyanate hardeners

AIP Conf. Proc. (June 2025)

On the mechanism of physical and chemical interactions of components of composite polymer materials filled with inorganic and organic ingredients

AIP Conf. Proc. (June 2025)

Development of technology for the production of hot-rolled heat-strengthened metal composite fittings of class A500C based on local and secondary raw materials

AIP Conf. Proc. (June 2025)

Determination of Optimum Geometrical Parameters of the Working Bodies of Cotton Processing Machines and Mechanisms

Soyibjon Negmatov¹, Nodira Abed¹, Olim Eshkobilov^{2, a)}, and Shokhista Karshiyeva²

¹State Unitary Enterprise “Fan va tarakkiyot” at Tashkent state technical university named after Islom Karimov, Tashkent, Uzbekistan

²Karshi Engineering Economic Institute, 180100, Karshi, Uzbekistan

^{a)} Corresponding author: polegon@11mail.ru

Abstract. Designs of machine-building parts made of structural composite polymer materials for the working bodies of cotton machines and mechanisms have been developed, having a curved surface along the perimeter and a spherical rounding in the head, facilitating minimal resistance to their introduction into the thickness of the mass of raw cotton. The optimal geometric parameters of pegs made of structural composite polymer materials have been determined, depending on the performance of the machines and the forces acting on the end of the pegs. Experimental studies were conducted to study the influence of various fillers on the physical, mechanical and tribotechnical properties of the compositions, and optimal filler contents were established to ensure the best properties of polystyrene and polyamide structural composite materials. The principle of designing impact-resistant, antifriction and antifriction-wear-resistant polystyrene and polyamide structural composite materials is proposed. Highly efficient structural composite materials for functional purposes based on thermoplastic polymers and fillers of different structures and nature have been developed, having sufficiently high strength and tribotechnical characteristics and have found application in the working bodies of cotton machines and mechanisms of the cotton processing industry operating under conditions of friction and wear.

Keywords. Raw cotton, polymer, strength, viscosity, hardness, modulus of elasticity, coefficient of friction, power consumption, damage to fibers, crushing of seeds.

INTRODUCTION

Currently, cotton gins and procurement points operate receiving and feeding mechanisms of the PLA brand, mobile cotton reloaders of the HPP brand, cotton riot pickers of the RP brand, pneumomechanical cotton pickers, swarming machines of the OBT brand to perform loading and unloading and transport operations, as well as preventive operations during transportation, acceptance and storage of raw cotton (Fig. 1-4) [1,2].

The working bodies of these mechanisms are equipped with scooping elements made in the form of spikes, having a spear-shaped shape and made of expensive and scarce metals (stainless steel) [3].

The use of such mechanisms has led to a significant reduction in labor costs, improved working conditions, and increased efficiency in loading and unloading operations at procurement and Azov procurement points [4]. However, research and operational experience, as well as studies on mechanization in raw cotton handling, indicate that these mechanisms have several inherent drawbacks. These include relatively low productivity and high-power consumption, which are embedded in their design [5]. Specific disadvantages of the mechanisms used for loading and unloading include fiber damage and crushing of cotton seeds, as well as the formation of free fiber. These issues arise from the impact of metal spike working bodies with raw cotton. Additionally, mechanisms with steel working bodies pose the risk of igniting raw cotton and generating sparks upon contact with solid and heavy impurities in the cotton [6,7].

Addressing or minimizing these shortcomings is a pressing issue. Solving these problems will significantly enhance the efficiency and effectiveness of the mechanisms while preserving the natural properties of raw cotton [8,9]. To eliminate or minimize these disadvantages, it is necessary to give the surface of the working bodies certain damping properties that allow them to soften their collision with raw cotton, which will significantly reduce the crushing of seeds and the damage to the fiber. This can be achieved by replacing metal spike working bodies with

intelligent working bodies of optimal design made of composite polymer materials [10].

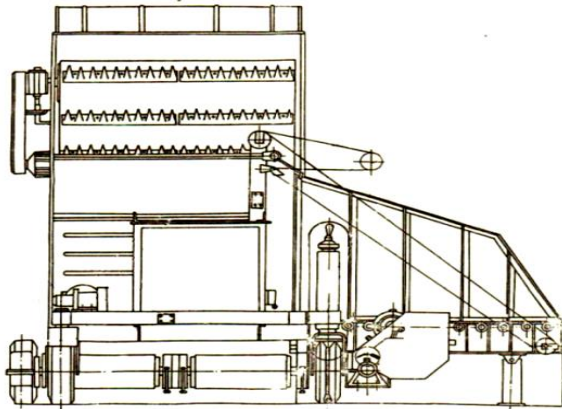
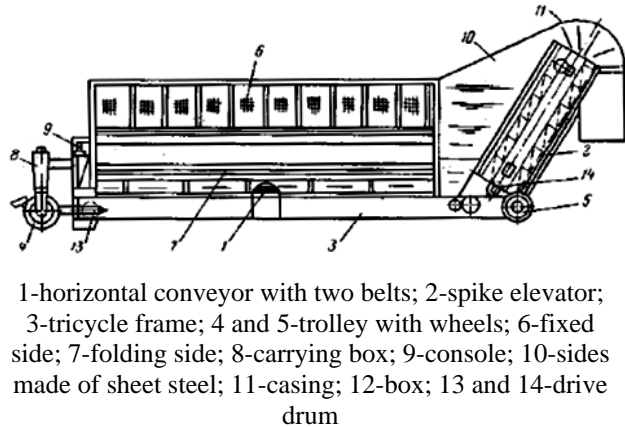
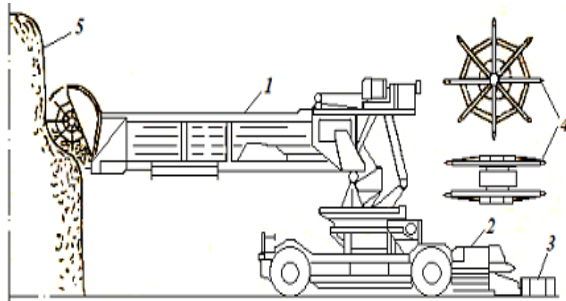

FIGURE 1. The scheme of a mobile cotton loader (HPP).



1-horizontal conveyor with two belts; 2-spike elevator; 3-tricycle frame; 4 and 5-trolley with wheels; 6-fixed side; 7-folding side; 8-carrying box; 9-console; 10-sides made of sheet steel; 11-casing; 12-box; 13 and 14-drive drum

FIGURE 2. The scheme of the receiving-feeding mechanism (PLA).



1-RP feeder disassembler; 2-belt conveyor; 3-pipeline; 4- roller working body; 5- riot of raw cotton.

FIGURE 3. The scheme of operation of the RP feeder disassembler.

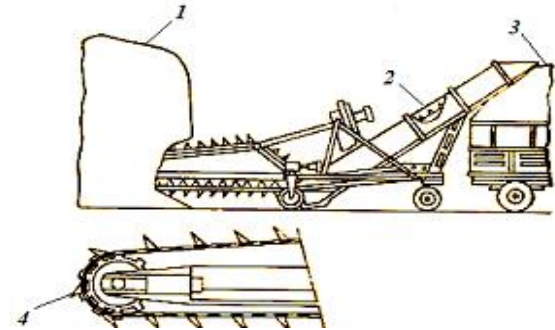

1-a riot of raw cotton; 2- a tunneling machine of the OB brand; 3- a trailer; 4- a roller working body of the machine.

FIGURE 4. The scheme of the tunneling machine OBT.

MATERIALS AND METHODS

For the manufacture of parts of rubbing pairs (pegs) of working bodies of cotton machines and mechanisms, impact-resistant polystyrene (IRPSC) and impact-resistant polyamide (IRPAC), wear-resistant polyamide compositions (WRPAC) have been developed and original technological principles for creating composite polymer materials (CPM) with specified properties have been implemented in order to comprehensively assess their performance in various friction units of machines and mechanisms of the cotton complex [11].

The current level of development of composite polymer materials (KPM) makes it possible to create unique materials that are workable in extreme conditions at low and elevated temperatures, pressures, aggressive and abrasive environments. The trend in the development of this area is the creation of highly filled, reinforced and especially durable KPMS with adjustable performance indicators for structural, special and multifunctional purposes [12].

However, existing polymer materials and compositions based on them are not yet widely used in the working bodies of machines and mechanisms of various branches of mechanical engineering, in particular, in cotton processing industry equipment due to the lack of developments to create reliable impact-resistant, wear-resistant, antifriction and antifriction-wear-resistant composite polymer materials based on local resources and effective technology for their production, as well as the manufacture of machine-building products and parts for structural and special purposes from them [13,14].

For impact-resistant materials, a necessary property is high impact resistance (IR), for wear-resistant composite materials (WRCM) - a low coefficient of friction with raw cotton, for antifriction-wear-resistant composite materials (AWRCM) - low coefficient of friction and low wear of the material when rubbing with raw cotton [15].

Based on the fact that the friction of polymer materials with raw cotton has a molecular - mechanoelectric nature, the obtained research results will allow us to change and regulate the properties of materials in a targeted manner, ensuring their compliance with the requirements for composite polymer materials operating in interaction with raw cotton [16].

Of the selected materials for research, polyamide (PA) has the best antifriction properties, so they can serve as a matrix of composite materials for antifriction purposes, and impact-resistant polystyrene (IRPS) has the best impact strength and hardness [17].

When choosing a filler for impact-resistant composite materials (IRCM), it is necessary to take into account its effect on specific viscosity. For impact-resistant composite materials based on PA and IRPS, the best fillers are fiberglass, cotton lint, and wollastonite. For ACM, it is necessary to take into account its influence on the coefficient of friction in a wide range of load, speed, humidity, clogging and grade, as well as the preservation of the quality indicators of raw cotton. The best fillers for the above materials are fillers – soot, graphite, talc, kaolin, wollastonite [18,19].

AICMS must meet the requirements of a minimum coefficient of friction and a minimum wear rate. As fillers for such materials, it is advisable to use asbestos, graphite, fiberglass (FG), cotton lint (CL), iron powder, cement, copper powder, kaolin, talc, soot, wollastonite [20].

Thus, scientific principles have been developed for the creation of polymer composite materials that can be used in the development of impact-resistant, antifriction and antifriction-wear-resistant polymer composite materials based on local raw materials and industrial waste.

The table shows the physico-mechanical and antifriction properties of the developed impact-resistant and wear-resistant composite polymer materials based on impact-resistant polystyrene and polyamide (table 1) [21,22].

TABLE 1. Properties of impact-resistant and wear-resistant composite materials.

Brands of composite materials	Indicators of the properties of composite materials				
	Bending strength, σ , MPa	Specific viscosity, kJ/m ²	Brinell hardness, HB, MPa	Modulus of elasticity, E, GPa	Coefficient of friction, f^*
IRPSC -1	56.9	25.3	145.0	3.0	0.36
IRPSC -2	62.3	27.5	135.0	2.9	0.345
IRPSC -3	65.8	30.8	145.0	2.8	0.34
IRPAC -1	108.0	137.6	84.0	2.1	0.35
IRPAC -2	110.3	139.0	85.7	1.95	0.33
IRPAC -3	112.2	140.7	86.3	2.0	0.31
WRPAC -1	99.7	130.8	87.2	1.85	0.32
WRPAC -2	100.3	132.3	87.2	1.90	0.31
WRPAC -3	101.8	135.5	89.5	2.05	0.33

* The coefficient of friction was determined by interaction with raw cotton with humidity $W= 8.2\%$, sliding velocity $V=1.5$ m/s and specific pressure $P=0.02$ MPa.

As can be seen from the table, the selected impact-resistant and wear-resistant composite polymer materials based on impact-resistant polystyrene and polyamide have sufficiently high properties that meet the requirements for the materials of the pegs of the working bodies of cotton machines and mechanisms operating under conditions of impact, friction and wear [23]. In this regard, it is advisable to recommend them for use in intelligent working bodies of cotton machines and mechanisms [24].

The productivity of machines and mechanisms was determined by the cut-off method, the force acting on the end of the stake was determined in accordance with the methodology given in [25].

RESULTS AND DISCUSSION

Experimental studies have been carried out to determine the optimal geometric parameters (angle of inclination, length and radius of curvature) pegs made of impact-resistant polyamide compositions (UPPAC-1 and UPPAC-2) of the working bodies of cotton machines and mechanisms, depending on their performance and the force acting on the end of the pegboard (Figures 1 and 2) [26].

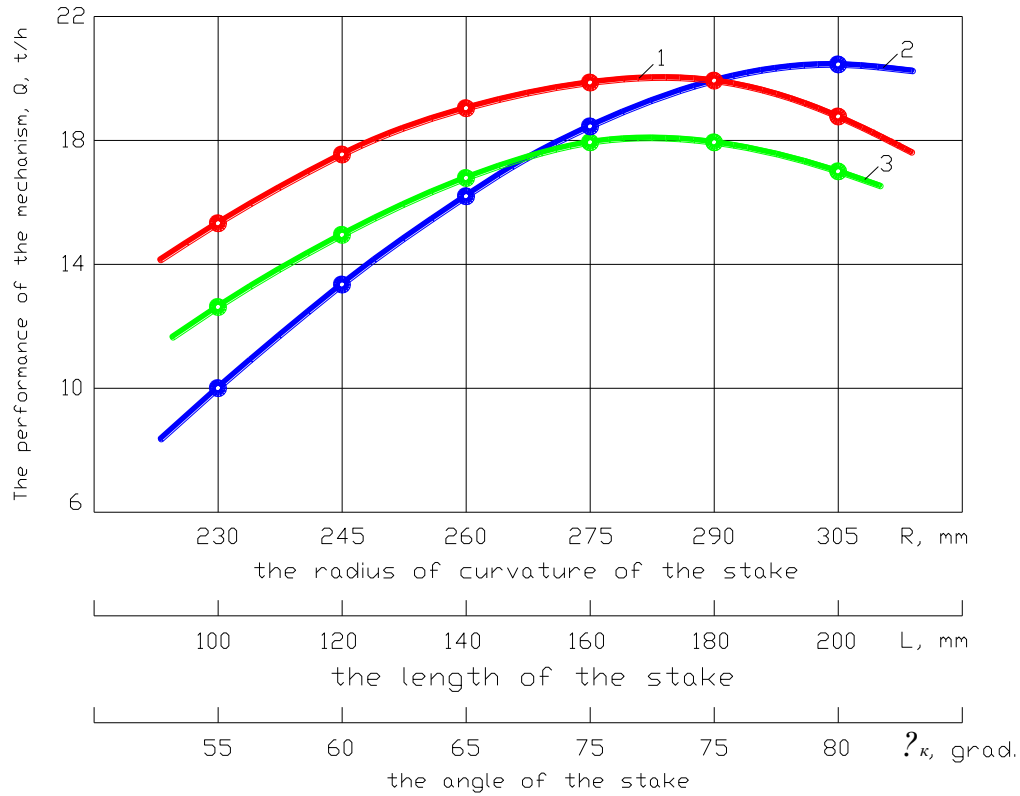

1- the length of the spike (L), 2- the radius of curvature (R), 3 –the angle of inclination (φ_{κ})

FIGURE 1. The dependence of the productivity of the mobile cotton loader on the geometric parameters of the stake from the IRPAC -1.

As can be seen from Fig. 1, the optimal values of the angle of inclination (φ_{κ}) to the horizon and the radius of curvature (R) of the stake are in the range of 65-70° and 270-275 mm, respectively [27]. With a decrease and increase in these values of the angle of inclination and the radius of curvature of the stake, the efficiency of capturing the mass of raw cotton decreases. The length of the spike (L) also affects the efficiency of capturing raw cotton. An increase in the length of the stake to 160 mm is accompanied by an increase in the captured mass of raw cotton, and a further increase in length is accompanied by a slight decrease in the mass of cotton. The angle of inclination at the top of the leading edge of the stake is 20-25° [28].

Figure 2 shows the dependences of the forces acting on the end of the spike made of impact-resistant polyamide composition (IRPAC-2) of a mobile cotton loader on its geometric parameters [29]. As can be seen from Fig. 3, with an increase in the radius of curvature of the peg to 275 mm, the force acting on the end of the peg increases, reaching a maximum, and further with an increase in the radius of curvature, the force acting on the end of the peg gradually decreases, due to the low coefficient of friction of the composite polymer material. As the length of the stake increases, the force acting on the end of the stake also gradually decreases, reaching a maximum with a length of 160-180 mm [30].

The force acting on the end of the stake gradually decreases as the angle of inclination increases, reaching a minimum at an angle of inclination of 60-70°, and then increases.

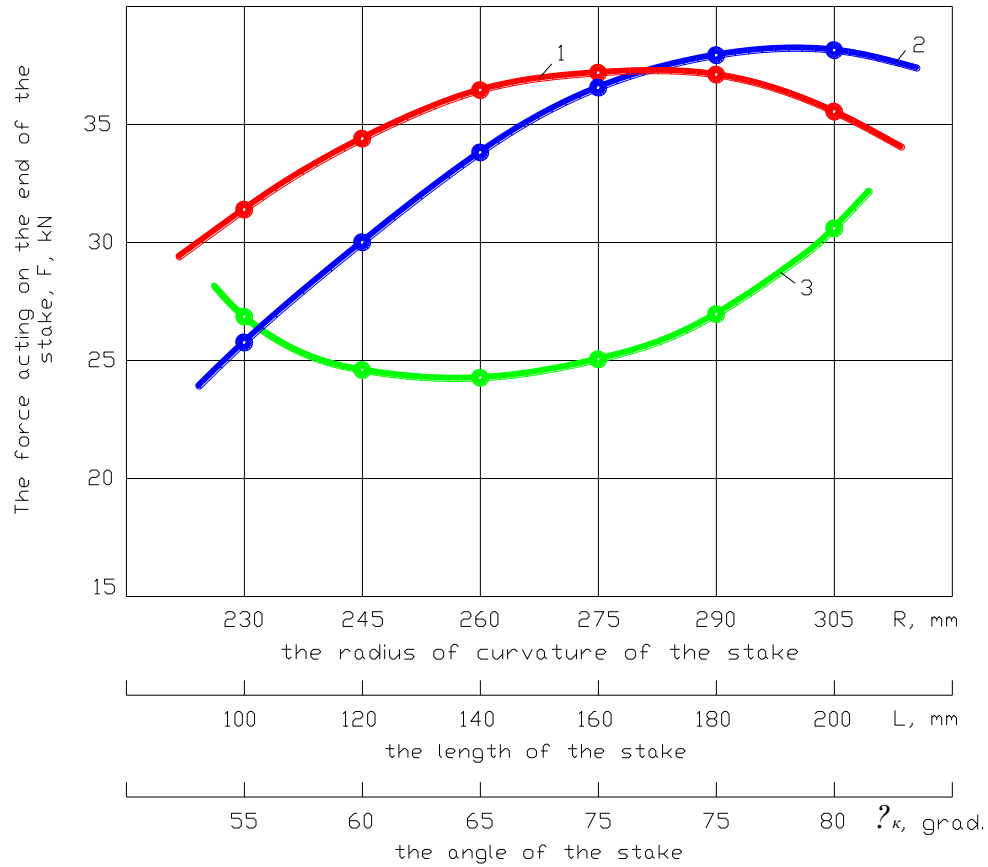

1- is the length of the stake (L), 2-is the radius of curvature (R), 3-is the angle of inclination (φ_{κ})

FIGURE 2. The dependence of the force acting on the end of the stake from the IRPAC -2 mobile cotton loader on its geometric parameters.

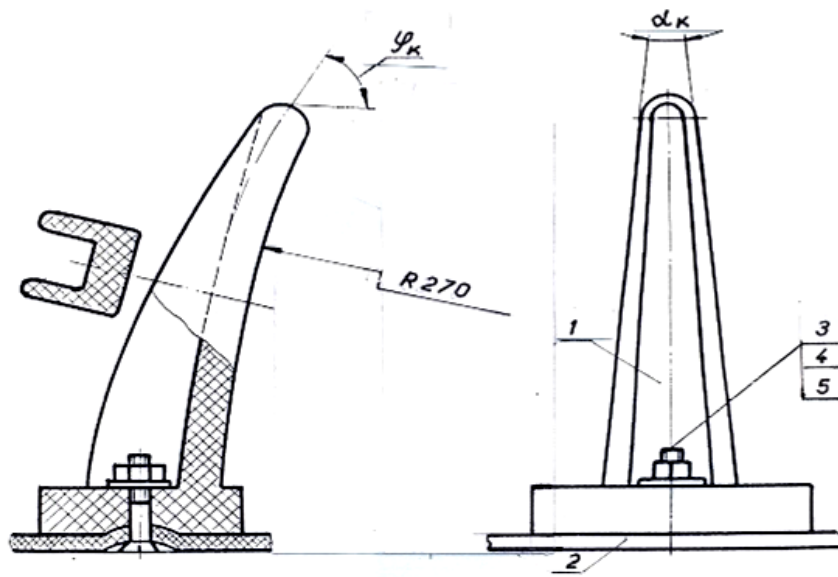

1- spike; 2-rubberized tape; 3-bolt,4- washer; 5 -nut.

FIGURE 3. Prefabricated spike of the working body of the mobile cotton loader of the HPP brand.

On the basis of these materials, the designs of the pegs of the working bodies of the mobile cotton loader of the HPP brand (Fig.3), the cotton riot disassembler of the RBD brand and the pneumomechanical cotton disassembler (Fig. 4) were developed [31].

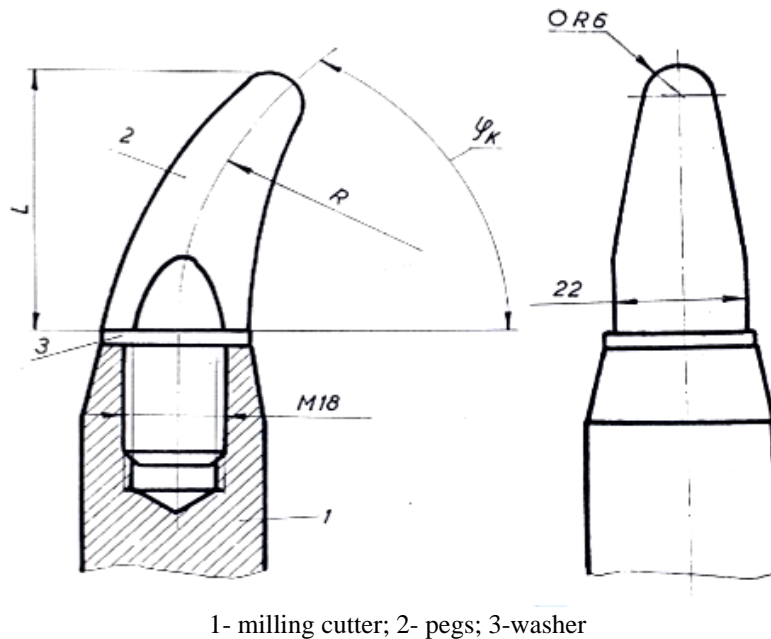

1- milling cutter; 2- pegs; 3-washer
FIGURE 4. Prefabricated pegs of the working body of the cotton riot picker and the pneumomechanical cotton picker.

A spike made of a high-impact polyamide composition (HIPAC-2), the working body of a mobile loader (Fig.3) is an exciting element made in the form of a rod with a spherical rounding in the head and with a trapezoidal profile in cross section from the head to the base. The radius of curvature of the stake is $R = 270-272$ mm, and at the base between the stiffeners of the profile there is a hole for a bolted connection and a recess with a radius of 40 mm [32].

The installation of pegs in the working body is carried out as follows. The pegs are pre-installed on the bar using bolted connections, then it is fixed to the tape of the working body of the mobile cotton loader. When replacing the pegs, it is enough to unscrew the nuts and the pegs are released from the bar [33].

A spike made of a wear-resistant polyamide composition (WRPAC-3), the working body of the cotton riot disassembler (Fig.4) is made in the form of a rod shaped like a truncated cone bent along the radius of curvature in the direction of rotation of the milling type working body. The radius of curvature is 70-75 mm. The pegs are assembled in the working body as follows. Pegs 2 with M18 thread are screwed to the pipe of the milling cutter 1 of the working body. When replacing the pegs, it is enough to unscrew them and the pegs are released from the milling cutter pipe [34].

Optimal geometric parameters of pegs made of structural composite polymer materials ensure their introduction into the thickness of the mass of raw cotton, contribute to increasing the productivity of the mechanism, reducing mechanical damage to fibers and crushing of raw cotton seeds, reducing power consumption and eliminating possible ignition of raw cotton [35].

The tests carried out in production conditions of pegs made of impact-resistant and wear-resistant composite polymer materials have shown that their use in the pegging working bodies of a mobile cotton loader, a cotton riot disassembler and a pneumomechanical cotton disassembler will significantly increase the reliability and performance of machines, reduce the damage to seeds and cotton fibers, reduce the formation of free fiber during the acceptance and transportation of cotton-raw cotton, as well as during preventive operations with raw cotton, eliminate the possibility of sparking and burning of cotton due to a decrease in the coefficient of friction of raw cotton when interacting with the working surface of a stake made of composite polymer material, improve the quality of the fiber produced.

CONCLUSION

Thus, the pegs of the working bodies of the mobile cotton loader and the cotton riot disassembler are made in the form of a curved hook bent in the direction of movement of the working body. In the head part, the pegs have a spherical rounding, which facilitates minimal resistance to the penetration of the pegs into the thickness of the mass of raw cotton. The angle of inclination of the stake to the horizon surface is $\varphi_k = 65-70^\circ$, and the angle between the side faces of the stake is $\alpha_k = 20 - 25^\circ$. This design of the stake improves the gripping ability, reliability and efficiency of the pegs of the working body when capturing raw cotton and disassembling the cotton riot, as well as when moving raw cotton to subsequent technological chains of machines and mechanisms, which increases machine productivity, reduces power consumption, reduces fiber damage and seed crushing and prevents the possibility of cotton burning-raw.

REFERENCES

1. Negmatov S.S. Operating conditions of the main working bodies of machines and mechanisms for harvesting and processing raw cotton. - Tashkent: Uzbekistan, 1980. – 64 p.
2. Gulyamov G., Negmatov S.S., Irgashev A.A. On the possibilities of using polyolefin compositions in intelligent working bodies of cotton machines. - Tashkent: Tashstu, 1992. -120 p.
3. Makhkamov R.G. Fundamentals of the process of interaction of surfaces of solids with fibrous mass. Tashkent, 1979. –96 p.
4. Negmatov S.S. Bases of processing of contact interaction of composite polymeric materials with fibrous mass. - Tashkent: Fan, 1984. -385 p.
5. Negmatov S.S., Abed N.S., Gulyamov G., Eshkobilov O.Kh. contact interaction [IOP Conference Series: Materials Science and Engineering](#), 1030, (2020). doi: 10.1051/e3sconf/202126405053.
6. Eshkobilov O.Kh. Investigation of the contact interaction of the working bodies of machines with raw cotton. [E3S Web of Conferences](#) 365, 04001, (2023). doi:10.1051/e3sconf/202336504001.
7. Abed N.S., Gulyamov G., Tuhtasheva M.N., Eshkobilov O.Kh. Engineering composite materials for the cotton processing industry. [E3S Web of Conferences](#) 264, 05053, (2021). doi: 10.1051/e3sconf/202126405053.
8. Gulyamov G., Eshkobilov O.Kh. Composite polypropylene polymer materials that work in contact with raw cotton. In [E3S Web of Conferences](#) 264, 05055 (2021). doi: 10.1051/e3sconf/202126405055
9. Abed N.S., Eshkobilov O.Kh., Negmatov S.S., Gulyamov G., Investigation of the Process of Electrification of Composite Polymer Coatings in the Case of Frictional Interaction with the Fibrous Mass. [AIP Conference Proceedings](#) 2432, 050009, (2021). Doi: 10.1063/5.0089709.
10. Tukhtasheva M.N., Eshqobilov O.Kh., Development of a disc tribometer and determination of its optimal parameters and modes of contact interaction of composites with raw cotton. [International Journal of Mechatronics and Applied Mechanics](#), 2021, Issue 10. pp. 214–221. doi: 10.17683/IJOMAM/ISSUE10/V1.28.
11. S.U.Sultanov, S.S.Negmatov, N.S.Abed, U.K.Kochkarov. Machine-building anti-corrosion composite polymeric materials and coatings based on local raw materials and production waste. [E3S Web of Conf.](#), 401 (2023) 05042. doi: 10.1051/e3sconf/202340105042.
12. Berdiyev Sh., Eshkabilov Kh. Structure and properties of the modified diffusion nitride-oxide surface layer. In [E3S Web of Conferences](#) 264, 05055 (2021). doi:10.1051/e3sconf/202126405054.
13. Kamolov B., Berdiyev Sh., Eshkabilov Kh. Hardening of cutting tools by combined gas nitriding method. [IOP Conference Series: Materials Science and Engineering](#), 1030(1), (2021) doi:10.1088/1757-899X/1030/1/012019.
14. Saipidinov A.A., Irgashev A.S., Negmatov S.S., Eshkabilov Kh.K. Modeling the process of real contact area formation during friction interaction of fibrous masses with polymer counterbody surface. *Soviet Journal of Friction and Wear*, 6(4), pp. 125-128 (1985)
15. Eshkabilov K. Structural-phase transformations during nitro oxidation of steels and surface properties. [E3S Web of Conferences](#), 2023, 401, 03014. doi: 10.1051/e3sconf/202340103014.
16. Eshkabilov K. Gradient structural-phase states and properties of surface layer after nitro-oxidation. [E3S Web of Conferences](#), 2023, 401, 03012. doi: 10.1051/e3sconf/202340103012.
17. Tukhtasheva M.N., Eshqobilov O.Kh., Investigation of antifriction properties of composite epoxy material in interaction with raw cotton. [International Journal of Mechatronics and Applied Mechanics](#), 2022, Issue 12. pp. 134–139. doi:10.17683/ijomam/issue12.20.
18. S.S.Negmatov, N.S.Abed, T.Ulmasov, B.Khaminov. Thermodynamic compatibility and structural characteristics of interpenetrating polymer vibration damping systems for engineering purposes. [E3S Web of](#)

- Conf., 401 (2023) 05095. doi:10.1051/e3sconf/202340105095.
19. S.S.Negmatov, N.S.Abed, S.Sultanov, K.Negmatova, M.Babakhanova, M.Matsharipova, G.Valiyeva, O.Madraximov, N.Umirova, M.Babakhanova, A.Nasriddinov; Anti-corrosion coating for engineering purposes. *AIP Conf. Proc.* 16 June 2022; 2432 (1): 050016. doi:10.1063/5.0090796.
 20. M.Ikramova, K.Negmatova, A.Khursanov, S.S.Negmatov, N.S.Abed, J.Negmatov. Development of composite chemical flotation reagents and their application in the process of flotation of copper-molybdenum ores. *AIP Conf. Proc.* 16 June 2022; 2432 (1): 050053. doi:10.1063/5.0090794.
 21. V.S.Tulyaganova, S.S.Negmatov, K.S.Negmatova, N.S.Abed, M.E.Ikramova, J.N.Negmatov, G.A.Sharipov, S.B.Yulchieva, A.R.Rajabov, E.Dustmuradov. Research of the properties of mineral ingredients and the possibility of applying them in producing the weighted drilling solutions applicable in drilling oil and gas wells under high filled pressures conditions. *AIP Conf. Proc.* 16 June 2022; 2432 (1): 050054. doi: 10.1063/5.0090823.
 22. Sergienko V.P., Bukharov S.N., Anisovich A.G., N.S. Abed, A.Ya.Grigoriev. The effect of a high-frequency electromagnetic field on dynamic mechanical and tribotechnical characteristics of frictional composites with a thermosetting polymer matrix. *J. Frict. Wear* 42, 401–407 (2021). doi:10.3103/S106836662106009X.
 23. Bukharov S.N., Tuleiko A.S., Sergienko V.P., Abed N.S., Alexiev A.R. Advanced sound absorbing materials to reduce noise and improve the environmental situation in production facilities and transportation. *New Technologies, Development and Application IV. NT 2021. Lecture Notes in Networks and Systems*, Vol. 233. Springer, Cham. doi: 10.1007/978-3-030-75275-0_50.
 24. A.Daminov, K.Negmatova, A.Umarov, N.S.Abed. Synthesis of diamonds in the C – Mn - Ni - (H) system and the diamond-shaped mechanism. *E3S Web of conference* 264, 05053 (2021).doi: 10.1051/e3sconf/202126405003.
 25. N.S.Abed, Negmatov S.S., Gulyamov G., Negmatov J.N. Antifriction wear-resistant composite materials and details made from them for working bodies of cotton machines and mechanisms. *Advanced Materials Research*, 616–618, 2005–2008. doi:10.4028/www.scientific.net/amr.616-618.2005.
 26. Gulyamov G., Abed-Negmatova N., Negmatov J., Yuldashev A., Eminov S., Bozorboev S., AripovaA., Negmatov S., Xojimuradov D. Composite polymer materials and the details made of them for cotton machines and mechanisms. *Advanced Materials Research*, 413, 535–538. doi:10.4028/www.scientific.net/amr.413.535.
 27. N.S.Abed, G.Gulyamov, S.S.Negmatov, D.M.Hodzhikariev, J.N.Negmatov, Sh.Sh.Eminov, Sh.Bozorbaev, A.Aripova, M.I.Negmatova. Durability of composite polymer materials working in contact with pulp. *AIP Conf. Proc.* 11 July 2012; 1459 (1): 283–285. doi:10.1063/1.4738470.
 28. Musabekov D., Abed-Negmatova, Gulyamov G., Shernaev A., Khodjimuradov D., Negmatov S. effective composite materials for friction pairs of working bodies of cotton machines. in *advanced materials research*. Vol.413, pp. 548–550. Trans Tech Publications, Ltd. doi: 10.4028/www.scientific.net/amr.413.548.
 29. A.Kh.Yuldashev, S.S.Negmatov, N.S.Abed, A.G.Abdurakhmanov, Sh.A.Bozorov, Sh.Sh.Eminov, A. Aripova, D.M. Khodjikariev. Melt index of low-density polyethylene and its effect on rotational molding. *AIP Conf. Proc.* 11 July 2012; 1459 (1): 344–346. doi:10.1063/1.4738491.
 30. S.S.Negmatov, A.N.Shernaev, G.Gulyamov, N.S.Abed, M.M.Saidov, D.H.Musabekov, M.I.Negmatova. Wear-resistant polymer composite filled with finely dispersed wood and carbon/graphite powders. *AIP Conf. Proc.* 11 July 2012; 1459 (1): 329–331. doi:10.1063/1.4738486.
 31. Kholikulovich E.O. Prevention of the flammability of raw cotton with the use of composite polymer coatings in friction units. *International Journal of Mechatronics and Applied Mechanics*, 2023, Issue 13. –P. 243–252.
 32. Alikulov, S., Eshkobilov O. Influence of the process of reserving filled containers of the cotton picker on the completeness of the cotton harvest. *E3S Web of Conferences*, 2023, 390, 06043. doi: 10.1051/e3sconf/202339006043.
 33. Eshkobilov O. Improved installation for determining antifriction properties of materials. *E3S Web of Conferences*, 2023, 401, 04024. doi: 10.1051/e3sconf/202340104024.
 34. Negmatov S.S., Abed N.S., Gulyamov G., Tuhtasheva M.N., Eshkobilov O.Kh., Karshieva Sh.Kh. Study of strength and coefficient of friction of composite materials in the process of contact interaction with raw cotton. *E3S Web of Conferences*, (2023).
 35. Abed N.S., Negmatov S.S., Eshkobilov O.Kh., Tuhtasheva M.N., Bozorboyev Sh.A. Research of the dependence of physical and mechanical properties on various technological parameters of injection molding in the formation of composite polymer materials. *E3S Web of Conferences*, (2023).