

RESEARCH ARTICLE | NOVEMBER 04 2025

Modeling the efficiency of photovoltaic and photothermal batteries using python software **FREE**

Muxamad Tursunov; Xabibullo Sabirov; Uygun Kholov ✉; Komil Kholiqov; Mansur Eshmatov

AIP Conf. Proc. 3331, 030062 (2025)

<https://doi.org/10.1063/5.0307217>



View
Online



Export
Citation

Articles You May Be Interested In

The algorithm for finding the normal state of the power system when the capacity of a power plant operating on renewable energy sources decreases

AIP Conf. Proc. (November 2025)

Webinar From Noise to Knowledge

May 13th – Register now



Zurich
Instruments

Universität
Konstanz

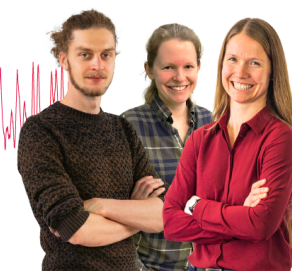

Modeling the efficiency of photovoltaic and photothermal batteries using Python software

Muxamad Tursunov¹, Xabibullo Sabirov¹, Uygun Kholov^{1, 2,a)}, Komil Kholiqov²,
Mansur Eshmatov^{1,3}

¹*Academy of Sciences of the Republic of Uzbekistan, Physical-technical institute, Tashkent, Uzbekistan*

²*Karshi engineering-economics institute, Karshi, Uzbekistan*

³*Turon university, Karshi, Uzbekistan*

^{a)} *Corresponding author: uygunshams@mail.ru*

Abstract. Photoelectric batteries have the ability to convert the flow of solar radiation directly falling from the sun to the earth's surface into electrical energy, and provide the needs of all production facilities and the population. However, external factors (air temperature, solar radiation and various types of dust) affect the efficiency of photoelectric batteries. By reducing the above-mentioned effects, it is possible to achieve an increase in the efficiency of the production of electric energy and an increase in the service life of photoelectric batteries. In this paper, to improve the performance of the photovoltaic battery, a study was conducted on cooling through a parallel channel cellular polycarbonate heat collector. In addition, studies were conducted using a reflector to increase the amount of solar radiation falling on the front surface of the photoelectric battery (close to the value in the reference of the photoelectric battery, i.e. 1000 W/m²) and to protect against night dusting.

INTRODUCTION

The use of renewable energy systems is rapidly developing worldwide due to the depletion of reserves and fluctuations in oil and gas prices worldwide. Given the sharp increase in CO₂ and other harmful gases in the atmosphere [1], the agreement of the international Paris Convention on the minimum cost of electricity production and reducing the impact of various emissions on the environment was signed. In addition, at the 26th meeting of the United Nations Framework Convention on Climate Change (COR26) held in November 2021, within the Paris Agreement, the Republic of Uzbekistan announced that by 2030 the gross domestic made a statement that it will undertake an additional commitment to reduce greenhouse gas emissions per unit of production by 35% compared to 2010 levels [2].

The easiest and most convenient way to protect the environment from the percentages indicated in this agreement is the use of photovoltaic batteries (PVBs). PVBs are one of the economically and ecologically promising technologies for converting solar energy directly into electricity [3]. However, we all know that the cost of using PVBs is more expensive than electricity generated using conventional fuels. When using PVBs, compared to traditional fuels, it is a convenient and easy way to protect the environment from various harmful wastes for human health [4]. In addition, the cost of electricity generation is further reduced when various cooling methods are used to increase the efficiency of PVBs. Several cooling methods are being used to increase the energy efficiency of PVBs by using different cooling technologies [5-13].

RESEARCH DEVICE AND DESCRIPTION

Currently, two types of cooling technologies are mainly used. It is passive cooling that uses natural convection and conduction to reduce excess heat, requiring electricity or conventional fuel to forcefully move the coolant [14, 15]. The use of an active cooling system increases the electrical energy efficiency of the PVB, and useful thermal

energy is produced based on the extraction of the excess heat of the PVB with the cooling liquid. As a result, the purpose of the research is solved. For this purpose, a new version of the photothermal battery (PTB) based on a comprehensively improved photoelectric battery was developed. A 340 W PVB based on monocrystalline silicon was chosen for the development of the device. Figure 1 shows axonometric and cross-sectional views of PTB made on the basis of PVB, consisting of different components [16].

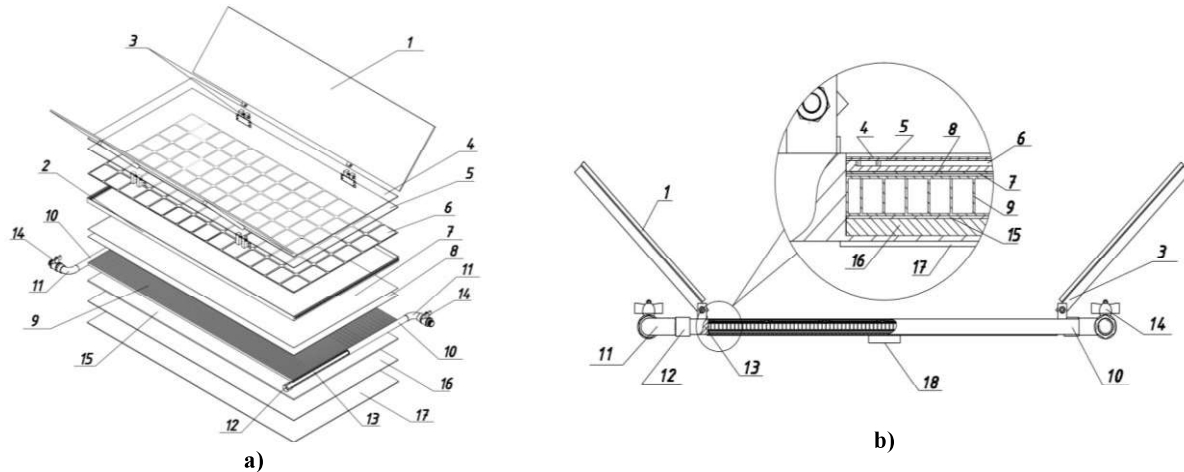

FIGURE 1. a) axonometric and b) cross-sectional view of PTB
 1- reflector, 2- PVB main body corpus, 3- bolts with double nuts, 4-PVB (4- protective glass, 5,7- front and back lamination layer, 6-SEs, 8- rear protective film (tedlar), 9- parallel channel cellular polycarbonate, 10- polymer tube, 11- copper metal threaded adapter, 12- corks, 13- slit, 14- faucets, 15- folgoizol, 16- foam plastic, 17- back cover, 18- terminal box.

Here is a brief description of the device. It is possible to get both electricity and hot water at the same time from PTB developed in a new design. The heat sink collector cooling the back surface of the PVB has an improved simplicity that requires less cost and less time to manufacture. The slit which was attached to polycarbonate channels is opened with a milling machine. A copper metal threaded adapter and water inlet and outlet control valves and plugs are firmly glued to both opposite exposed ends of the pipe using an iron. The heat collector is filled in the thickness of the aluminium body, and bent inward at right angles, which ensures the stability of the heat collector, foil and foam plastic photoelectric battery.

An outer back cover made of alucobond is attached to the body to balance all the materials in close contact with the back surface of the photovoltaic battery. In order for the heat collector to completely cover the back surface of the photoelectric battery, cold water inlet and hot water outlet polymer pipes and faucets are placed outside the body, which maintains its strength. Reflectors made of Alucobond (one side of which is sticky on the reflecting surface and the other side of shiny foil is glued) concentrate solar radiation on the frontal surface of the photothermal battery and protect against dust falling at night. The reflectors are fixed to the photoelectric battery housing with the help of double-nut bolts. In addition, the double nut bolts ensure that the reflectors are balanced at the same time, that there are no inconveniences when opening and closing, and that the shadow does not fall on the front surface of the photoelectric battery [16].

EXPERIMENTAL RESEARCH

The experimental results obtained using the developed device were modeled in Python in order to compare them with theoretical results. External parameters (weather temperature, wind speed, air stability, geographic latitude and longitude) were obtained from the international database (OWM-Open Weather Maps) using the Python program. In the Python program, all the parameters needed to compare the results obtained from the device with the theoretical results are listed in the control window (Figure 2). The values of some fixed and variable quantities of the developed PTB in improving the energy efficiency of the PVB are presented in Figure 2. Water was used as a cooling liquid during the experiment. The hot water from the hot water collector can be used for household needs of the population. The modeling results were compared with the results of the research conducted in the conditions of the city of Karshi. The geographic latitude of Karshi is 39° and longitude is 69°, as shown in Figure 2.

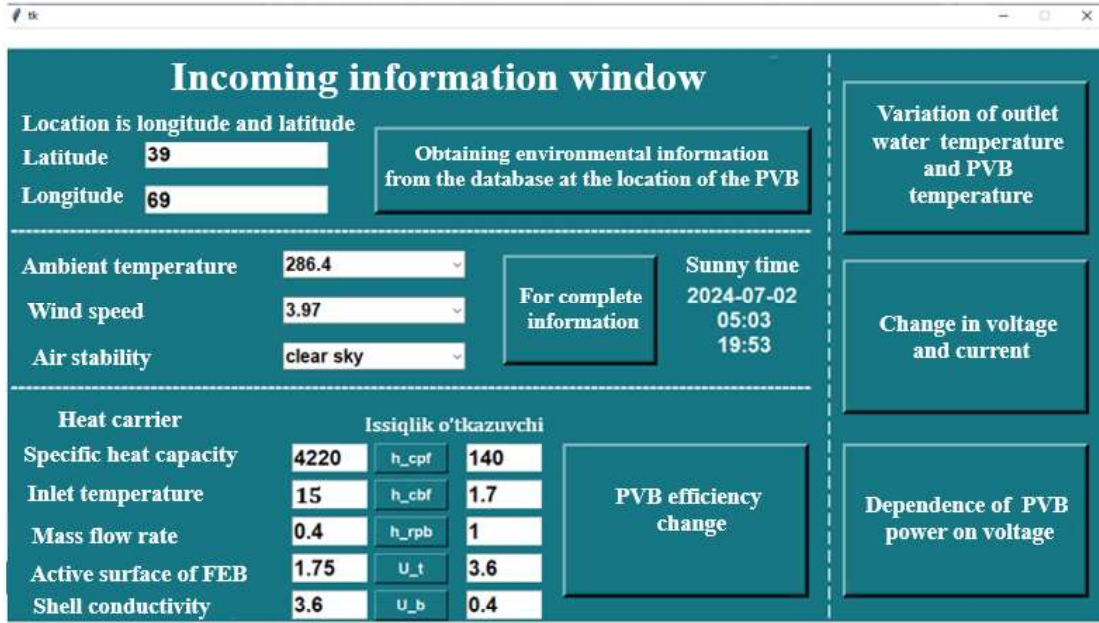

FIGURE 2. An overview of the Python data window

A day was taken for the modeling process. The results for one day are also presented in the graphs. PTB's performance status only shows the change of results during sunny hours. In the absence of the sun, it was observed that the cooling liquid (water) was adapted to the initial temperature of the inlet, and the temperature of the PTBs to the night air temperature. Therefore, the control window also shows the value of ambient temperature and wind speed at 05:10 in the morning. Based on the compared results, the efficiency of the FEB was determined as follows [17]:

$$\eta_{PV} = \eta_o [1 - 0.0045(T_p - 298K)] \quad (1)$$

here, T_p – solar cell temperature; η_o – efficiency under conditions of PVB (standard test conditions). The results obtained during the modeling are presented in Figures 3 a and b.

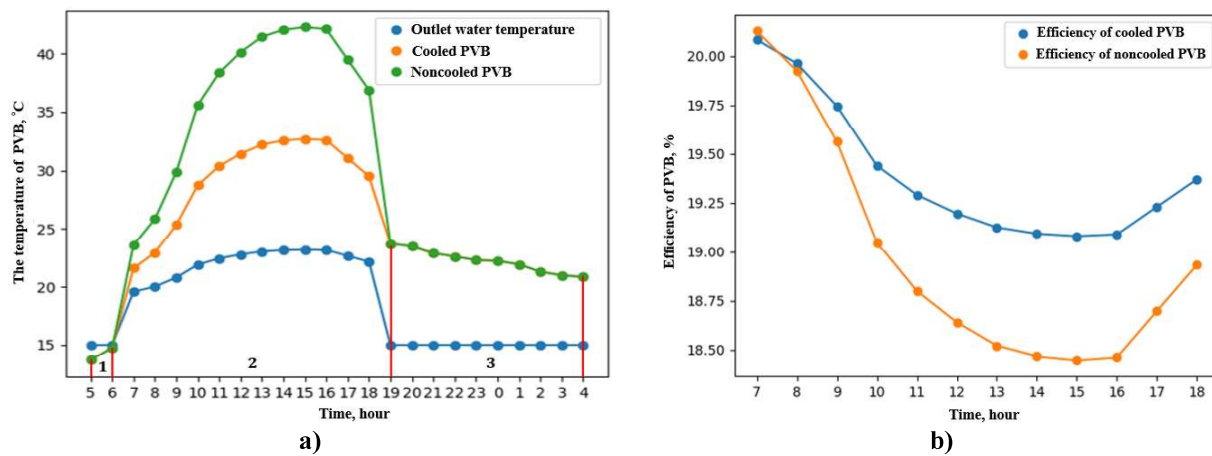

FIGURE 3. a) PVB, PTB and water outlet temperature, b) Variation of efficiency during the day according to the electric energy efficiency of PVB and PTB

Figure 3a shows the variation of PTB temperature during one day in Python. Figure 3a shows the nighttime (no solar radiation flux) condition of the PTB in sections 1 and 3. And part 2 shows it in PTB mode on a sunny day. In this case, the blue curve shows the temperature of the hot water leaving the heat collector part of the PTB, and the yellow, green curves show the temperature of the cooled and uncooled PVB. When the temperature of the water in

the coolant inlet tap of the heat collector part of the PTB is 15 °C, hot water with a temperature of 22 °C - 25 °C can be obtained during the average day. As a result, it was determined that the temperature difference between cooled and uncooled FEBs is equal to 7,5 °C - 10 °C. During cooling of cooled and uncooled PVBs, the efficiency was found to be 1,5% to 2% higher when the temperature difference varied from 7,5 °C to 10 °C (Fig. 3b). In addition, the environment is protected from various harmful gases released when traditional fuel is used to raise the temperature of hot water from the heat collector to 22 °C - 25 °C during the day [18, 19]. Figures 4a, b shows the results of I-V and P-V of PVB and PTB.

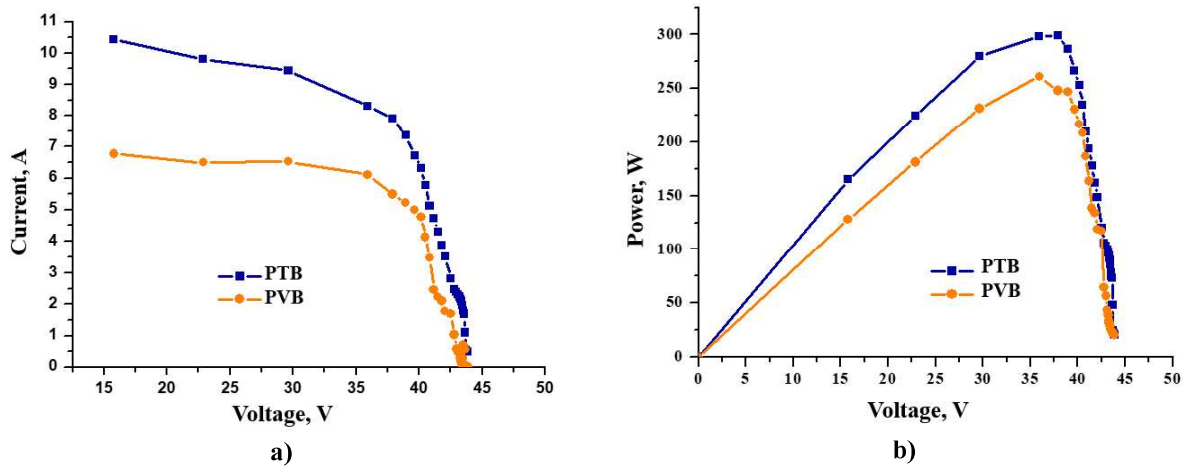

FIGURE 4. a) volt-ampere characteristics (VAC) of PTB and PVB and
b) volt-watt characteristics (VWC) of PTB and PVBs

In Figure 4, it can be seen that PTB has a higher electrical energy efficiency than PVB. When PVB is used in PTB mode, high energy (both electrical and thermal) efficiency is achieved [20-25].

CONCLUSION

By increasing the speed of water entering the heat collector, the efficiency of the PTB system was further improved. The results of the study revealed that the effectiveness of the active cooling method is higher than that of passive cooling. In a natural conditions study, PTB performed better than PVB even in high wind conditions. It was found that the possibility of good performance is high when the temperature on the back surface of PVB is kept to the value of the passport data (25 °C) and the solar radiation flux falling on the front surface is 1000 W/m². Due to the use of water as a cooling liquid and reflectors that increase the flow of solar radiation, the electric energy efficiency of PVB compared to PTB was achieved by 12-15%, and the thermal efficiency was increased by 20-50%. In addition, it was found that hot water of 28-36 °C can be obtained from PTB even on cold sunny days (due to the lack of natural convective heat exchange with the external environment due to the use of heat-insulating materials on the back surface of the PVB).

REFERENCES

1. Tursunov M.N., Sabirov. X., Xolov U.R. Protecting the environment from greenhouse gases using an autonomous photothermal device. *Journal of alternative energy*. 2023, 2/09 pp. 22-27.
2. Decision of the President of the Republic of Uzbekistan dated December 2, 2022 No. PQ-436 "On measures to increase the effectiveness of reforms aimed at the transition of the Republic of Uzbekistan to a "green" economy until 2030".
3. Hasanuzzaman, M., et al.: Global advancement of cooling technologies for PV systems: A review. *Solar Energy*. 2016, №137, pp.25–45. <https://doi.org/10.1016/j.solener.2016.07.010>
4. Diab A.A.Z., Rezk, H. Global MPPT based on flower pollination and differential evolution algorithms to mitigate partial shading in building integrated PV system. *Solar Energy*, 2017, №157, pp.171-186. <https://doi.org/10.1016/j.solener.2017.08.024>

5. El-Seesy, I.E., Khalil, T.M., Ahmed, T. Experimental investigations and developing of photovoltaic/thermal system. *World Appl. Sci. J.*, 2012, №19(9), pp.1342-1347. <https://doi.org/10.5829/idosi.wasj.2012.19.09.2794>
6. Masoud, R., Morteza, E., Alireza, R. An experimental study on natural vaporization for cooling of a photovoltaic solar cell. *Int. Commun. Heat Mass Transfer*, 2015, №65, pp. 22-30. <https://doi.org/10.1016/j.icheatmasstransfer.2015.04.002>
7. Hou, L., et al. An experimental and simulative study on a novel photovoltaic-thermal collector with micro heat pipe array. *Energy Build.*, 2016, №124, pp. 60–69. <https://doi.org/10.1016/j.enbuild.2016.03.056>
8. Hussein A.A., Numan A.H., Abdulrahman, R.A. Improving the hybrid photovoltaic/thermal system performance using water-cooling technique and Zn-H₂O nanofluid. *International Journal Photo-Energy*, 2017, p. 1-14. <https://doi.org/10.1155/2017/6919054>
9. Odeh, S., Behnia, M. Improving photovoltaic module using water-cooling. *Taylor and Francis-Heat Transfer Eng.* 2010, №30(6), pp. 499–505. <https://doi.org/10.1080/01457630802529214>
10. Sweidan, T.O. Dynamical analysis of DC shunt motor powered by PV generator using perturbation and observation as MPPT tracking technique. *Energy and Power Eng.*, 2017, №09(1), pp. 55–69. <https://doi.org/10.4236/epe.2017.91005>
11. Sweidan, T.O., Widyan, M.S.: Perturbation and observation as MPPT algorithm applied on the transient analysis of PV-powered DC series motor. 8th International Renewable Energy Congress (IREC) Amman, 2017, pp. 1–6 <https://doi.org/10.1109/IREC.2017.7926023>
12. Arcuri, N., Reda, F., De Simone, M. Energy and thermo-fluid-dynamics evaluations of photovoltaic panels cooled by water and air. *Solar Energy*, 2014, №105, pp. 147-156. <https://doi.org/10.1016/j.solener.2014.03.034>
13. Tang, X., Quan, Z., Zhao, Y.: Experimental investigation of solar panel cooling by a novel micro heat pipe array. *Energy and Power Eng.*, 2010, №02, pp. 171-174. <https://doi.org/10.1109/APPEEC.2010.5449518>
14. Bruno Meneghel Zilli, Anderson Miguel Lenz, Samuel Nelson Melegari de Souza, Deonir Secco, Carlos Eduardo Camargo Nogueira, Oswaldo Hideo Ando Junior, Willian César Nadaleti, Jair Antonio Cruz Siqueira, Flavio Gurgacz. Performance and effect of water-cooling on a microgeneration system of photovoltaic solar energy in Parana, Brazil. *J. Cleaner Prod.*, 2018, №192, pp. 477–485. <https://doi.org/10.1016/j.jclepro.2018.04.241>
15. Niyozov, N., Khushbokov, B., Saidova, G.E., Bakhadirov, I. (2024). *Energy efficiency of concrete work technology*. AIP Conference Proceedings, **3152**(1), 030025. <https://doi.org/10.1063/5.0218841>
16. Niyozov, N., Sattarov, K., Bazarbayeva, A., Kamalov, U. (2024). *Energy Efficiency of Automated Control of Artificial Lighting*. AIP Conference Proceedings, **3152**(1), 050026. <https://doi.org/10.1063/5.0218843>
17. Niyozov, N., Saburov, S., Ganiyev, Sh., & Olimov, Sh. (2023). AI-powered learning: Revolutionizing technical higher education institutions through advanced power supply fundamentals. *E3S Web of Conferences*, 403, 01092. <https://doi.org/10.1051/e3sconf/202346101092>
18. Niyozov, N., Bijanov, A., Ganiyev, Sh., & Kurbonova, R. (2023). The pedagogical principles and effectiveness of utilizing ChatGPT for language learning. *E3S Web of Conferences*, 403, 01093. <https://doi.org/10.1051/e3sconf/202346101093>
19. Niyozov, N. N., Rikhsitillaev, B. Kh., Jalilova, D. A., & Kuvatbaev, P. M. (2023). Forecasting of electricity consumption by industrial enterprises with a continuous nature of production based on the principal component method (PCA). *E3S Web of Conferences*, 383, 01031. <https://doi.org/10.1051/e3sconf/202338401031>
20. Tursunov M.N., Sabirov. X., Xolov U.R., Eshmatov M.M. Full thermal contact photothermal battery with parallel channel polycarbonate collector, № FAP 2492, 10.05.2024.
21. Arbuzov Yu.D., Evdokimov V.M. Fundamentals of photoelectricity, *M. Science*, 2007, pp. 222-231.
22. Kholov U.R. Study of annual energy efficiency using the active cooling method of the photoelectric battery/ National academy of scientific and innovative research. *Science and education: modern time*. 2024, pp. 22-30. <https://doi.org/10.5281/zenodo.10882905>
23. M. N. Tursunov, X. Sabirov, U. R. Xolov, M. Eshmatov. Investigation of the Parameters of a Photovoltaic Thermal Battery in Extreme Natural Conditions. *Applied Solar Energy*, pp. 272–277. <https://doi.org/10.3103/S0003701X21040113>
24. Muminov R., Tursunov M., Yuldoshev I., Sabirov X., Kholov U., Akhtamov T. Features of optimization of increasing the efficiency of an autonomous photo thermal installation for rural regions. *E3S Web of Conferences* 216, 01146 (2020) RSES, <https://doi.org/10.1051/e3sconf/202021601146>
25. Tursunov M.N., Yuldoshev I.A., Sabirov X., Xolov U.R. Evaluation of energy efficiency of photoelectric heat batteries with mechanism of solar observation. *Technical science and innovation*, 2022, pp.100-106. ISSN: 2181-0400