

4-29-2023

MATHEMATICAL DESCRIPTION OF A BLEACH IMPREGNATION RESERVOIR

Bekobod Ibragimov

Karshi Engineering Economics Institute. Address: 180100, Mustakillik avenue, 225, Karshi city, Kashkadarya region, Republic of Uzbekistan. E-mail: ibragimovbekobod@gmail.com., ibragimovbekobod@gmail.com

Follow this and additional works at: <https://ijctcm.researchcommons.org/journal>

 Part of the [Complex Fluids Commons](#), [Controls and Control Theory Commons](#), [Industrial Technology Commons](#), [Other Engineering Commons](#), and the [Process Control and Systems Commons](#)

Recommended Citation

Ibragimov, Bekobod (2023) "MATHEMATICAL DESCRIPTION OF A BLEACH IMPREGNATION RESERVOIR," *Chemical Technology, Control and Management*. Vol. 2023: Iss. 2, Article 11.
DOI: <https://doi.org/10.59048/2181-1105.1451>

This Article is brought to you for free and open access by Chemical Technology, Control and Management. It has been accepted for inclusion in Chemical Technology, Control and Management by an authorized editor of Chemical Technology, Control and Management. For more information, please contact app-tgtu@mail.ru.



ISSN 1815-4840, E-ISSN 2181-1105

Himičeskaâ tehnologiâ. Kontrol' i upravlenie

CHEMICAL TECHNOLOGY. CONTROL AND MANAGEMENT

2023, №2 (110) pp.79-85.

International scientific and technical journal

journal homepage: <https://ijctcm.researchcommons.org/journal/>



Article history: Received 02 April 2023; Received in revised form 27 April 2023; Accepted 29 April 2023;
Available online 20 May 2023

Since 2005

MATHEMATICAL DESCRIPTION OF A BLEACH IMPREGNATION RESERVOIR

Bekobod Ibragimov

Karshi Engineering Economics Institute. Address: 180100, Mustakillik avenue, 225, Karshi city, Kashkadarya region,
Republic of Uzbekistan.

E-mail: ibragimovbekobod@gmail.com.

Abstract: This article discusses the issues of constructing a mathematical model of the technological process of bleaching textile materials in an impregnating reservoir using the heat balance equation, on the basis of which a qualitative analysis of the dynamic properties of an object has been carried out in order to create highly efficient control systems with the use of energy-saving technologies. While constructing a mathematical model characterizing the established and non-established modes of the control object (impregnating reservoir) used changes in heat flow and mass velocity of the incoming tissue. An algorithm for constructing a mathematical model of the process of bleaching cotton fabrics has been proposed. The results of solving a practical problem show the adequacy of the developed model.

Key words: textile materials, impregnation reservoir, bleaching of fabrics, heat balance, environment, thermal resistance, mathematical model, transfer function.

Аннотация: Иссиқлик баланси тенгламасидан фойдаланган ҳолда сингдирувчи ваннада тўқимачилик материалларини оқартириш технологик жараёнининг математик моделини яратиш масалалари, бунинг асосида объектнинг динамик хусусиятларини юқори даражада сифатли таҳлил қилиш учун энергия тежайдиган технологиялардан фойдаланган ҳолда самарали бошқариш тизимлари кўриб чиқилган. Бошқариш объекти (сингдирувчи ванна) нинг ўрнатилган ва ўрнатилмаган режимларини тавсифловчи математик моделини куришида иссиқлик оқими ва келадиган матоларнинг масса тезлигидаги ўзгаришлар ишлатилган. Пахта матоларини оқартириш жараёнининг математик моделини тузиш алгоритми таклиф қилинган. Амалий масалани ечиш натижалари ишлаб чиқилган моделнинг монанд эканлигини кўрсатди.

Таянч сўзлар: тўқимачилик материаллари, сингдирувчи ванна, матони оқартириш, иссиқлик баланси, атроф-муҳит, иссиқлик қаришилиги, математик модель, узатиш функцияси.

Аннотация: Рассмотрены вопросы построения математической модели технологического процесса отбеливания текстильных материалов в пропиточной ванне с применением уравнения теплового баланса, на основе которого осуществляется качественный анализ динамических свойств объекта с целью создания высокоэффективных систем управления с применением энергосберегающих технологий. При построение математической модели, характеризующей установившиеся и не установившиеся режимы объекта управления (пропиточной ванны) использованы изменения теплового потока и массовой скорости ткани. Предложен алгоритм построения математической модели процесса отбеливания хлопковых тканей. Результаты решения практической задачи показали адекватность разработанной модели.

Ключевые слова: текстильные материалы, пропиточной ванны, отбеливание тканей, тепловой баланс, окружающая среда, термическое сопротивление, математическая модель, передаточная функция.

Introduction

Nowadays, special attention is being paid to the textile material quality.

In the textile industry, the most labor-intensive are the technological processes for preparing the dosage of dyes and textile auxiliary utilities (TAU) for printing, dyeing and finishing of textile materials.

Improving the quality of production is largely determined by the level of automation of technological processes performed by technological units. An important stage in the modernization of existing or the development of new control systems for the investigated object is to determine the dynamic properties of the process.

There are a large number of works devoted to the issues and automation of dyeing processes,

which consider the issue of automatic maintenance of temperature, concentration and level of solutions, etc. [3].

For the quality management of bleaching processes in the textile and other industries, the issues of automatic regulation of the flow rate of liquid, bulk and viscous media are of paramount importance. The creation of automatic control systems in many cases is complicated by the lack of precise methods for synthesizing control algorithms that provide high accuracy and reliability for a long time.

To solve this problem, it is necessary to develop mathematical models of the controlled object. This paper presents the results of a study of the dynamic properties of an impregnating reservoir for bleaching fabrics in textile factories.

Solution methods

Meanwhile, much attention is paid to various chemical-technological processes in the textile industry, taking place in devices with increased pressure.

The reservoir is heated by means of a coil (or heating jacket), into which steam is supplied with a flow rate g (kg / s) and a specific enthalpy i_0 (kJ / kg). The wet cloth wrung out in the previous machine is also supplied to the reservoir with a mass rate of u_m (kg / s) and a feeding solution G_{II} (kg / s). The solution level is maintained at a given value H_0 by a level regulator supplying water G_6 (kg / s), and the solution concentration is controlled by a concentration regulator or a dosing device (Fig. 1).

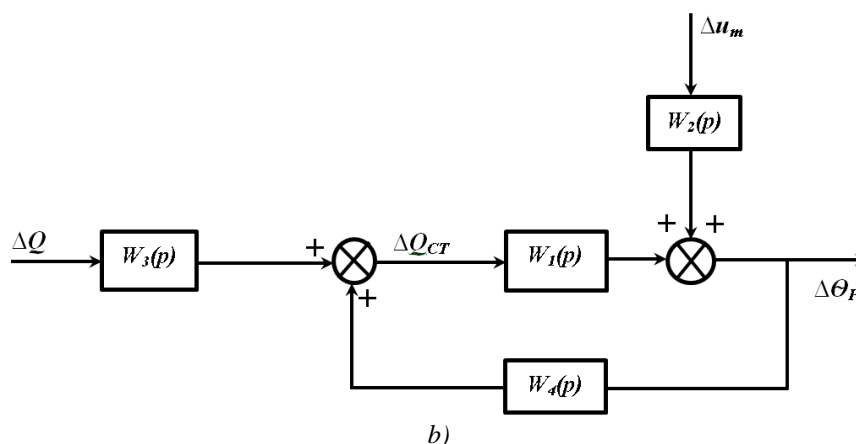
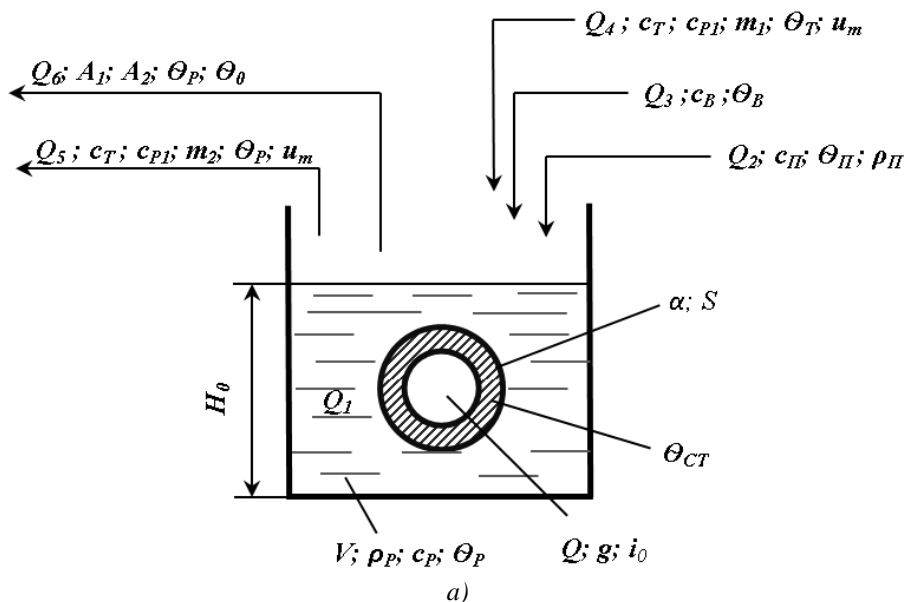

*Fig 1. Object for controlling temperature:
a - heat flow schema; b - structural mathematical model of the solution temperature control process.*

For the equilibrium state, the heat balance equations are written in the form

$$Q_{1_0} + Q_{2_0} + Q_{3_0} + Q_{4_0} - Q_{5_0} - Q_{6_0} = 0 \quad (1)$$

where $Q_1 = \alpha S(\theta_{CT} - \theta_p)$ — heat flux comprised by steam into the solution from the outer walls of the coil; $Q_2 = G_{II}c_{II}Q_{II}$ — heat flux introduced by the feed solution; $Q_3 = G_Bc_BQ_B$ — heat flow introduced by water; $Q_4 = u_m(c_T + c_{P_1} \cdot m_1)\theta$ — heat flux introduced by incoming tissue; $Q_5 = u_m(c_T + c_P \cdot m_2)\theta_p$ — heat loss with outlet tissue; $Q_6 = Q_6' + Q_6''$ — heat loss of the reservoir to the environment by heat transfer Q_6' and evaporation from the surface of the liquid Q_6'' .

In the previous expression, $Q_6' = A_1(\theta_p - \theta_0)$ a, $A_1 = \sum_1^n \alpha_i F_i$ where F_i and α_i is the area of the surface of the sides and bottom of the reservoir and the corresponding heat transfer coefficients. The loss Q_6'' depends nonlinearly on temperature, but within a certain temperature range in a linear approximation $Q_6'' \approx A_2\theta_p - A_3$.

Heat flows shown in Fig. 1, a , are determined in kilojoules per second (kJ / s). For these flows, the same as for the above expressions: θ_{CT} , θ_{II} , θ_p , θ_B , θ_T and θ_0 are the temperatures, respectively, of the walls of the coil, reinforcing and working solutions, added water, tissue and the environment, °C; c_{II} , c_T , c_P and c_{P1} - specific heat capacity of the reinforcing solution, tissue, working solution and solution, which impregnated the incoming tissue, kJ / (kg * ° C); a is the coefficient of heat transfer from the walls of the coil to the liquid, kW / (m² * ° C); S is the outer surface of the tubes, m². In further calculations, for simplicity, we will take $c_{P1} \approx c_P \approx c_B = 4.19$ kJ / (kg * ° C).

In an unsteady mode, the influx or consumption of heat changes, as a result of which the thermal energy of the reservoir accumulates or decreases. For the unsteady mode, we linearism the expressions for individual heat fluxes. The adjustable value is θ_p , the regulating effect is the steam consumption g . For the perturbation, we take the change in the mass velocity of the tissue, u_m etc.

Heat flow introduced by steam $Q = g(i_0 - i_K)$, where i_K - is the enthalpy of condensate removed from the coil. With a change in the heating steam supply ΔQ , the temperature of the coil wall θ_{CT} , the heat flux ΔQ_1 and the temperature θ_p will change. The coil filled with a steam-water mixture has a heat capacity C_1 (kJ / ° C). The process of changing the wall temperature θ_{CT} can be expressed by the equation

$$C_1 \frac{d(\Delta\theta_{cm})}{dt} = \Delta Q - \Delta Q_1 = \Delta Q - \frac{\Delta\theta_{cm} - \theta_p}{R_1}, \quad (2)$$

where $R_1 = 1/\alpha S$ — thermal resistance of the coil, ° C / kW.

Change in heat flow ΔQ_1 and mass velocity of the incoming tissue Δu_m and will lead to a change in θ_p and heat fluxes ΔQ_4 and ΔQ_5 introduced by the incoming and carried away tissue, and

also to a change in the heat loss of the reservoir room to the environment ΔQ_6 . In case

$$C_2 \frac{d(\Delta\theta_p)}{dt} = \Delta Q_1 + \Delta Q_4 - \Delta Q_5 - \Delta Q_6 \quad (3)$$

where $C_2 = V\rho_P c_P$ — heat capacity of the reservoir, kJ / ° C;

$$\begin{aligned} \Delta Q_1 &= \frac{1}{R_1}(\Delta\theta_{CT} - \Delta\theta_p); & \Delta Q_4 &= (c_T + c_{P_1} \cdot m_1)\theta_{T_0} \Delta u_m; \\ \Delta Q_5 &= u_{m_0}(c_T + c_P \cdot m_2)\Delta\theta_p + \Delta\theta_{p_0}(c_T + c_P \cdot m_2)\Delta u_m; & \Delta Q_6 &= (A_1 + A_2)\Delta\theta_p \end{aligned}$$

Let us represent $\Delta Q_4 - \Delta Q_5 - \Delta Q_6$ in the form of terms depending on $\Delta\theta_p$ and Δu_m . Overall

$$C_2 \frac{d(\Delta\theta_p)}{dt} = \frac{\Delta\theta_{cm} - \Delta\theta_p}{R_1} - \frac{\Delta\theta_p}{R_2} + F\Delta u_m, \quad (4)$$

where

$$R_2 = \frac{1}{u_{m_0}(c_T + c_P \cdot m_2) + (A_1 + A_2)}$$

has the dimension of thermal resistance ($^{\circ}C / kW$), and

$$F = (c_T + c_{P_1} \cdot m_1)\theta_{T_0} - (c_T + c_P \cdot m_2)\theta_{P_0}$$

Let us write equations (2) and (4) in operator form with zero initial conditions:

$$C_1 p(\Delta\theta_{CT}) = \Delta Q - \frac{\Delta\theta_{CT} - \Delta\theta_P}{R_1} \tag{5}$$

$$C_2 p(\Delta\theta_P) = \frac{\Delta\theta_{CT} - \Delta\theta_P}{R_1} - \frac{\Delta\theta_P}{R_2} + F\Delta u_m \tag{6}$$

Having solved this system of equations by substituting the value, from equation (5) into equation (6),

we obtain

$$R_1 C_1 R_2 C_2 p^2 \Delta\theta_P + (R_1 C_1 + R_2 C_2 + R_2 C_1) p \Delta\theta_P + \Delta\theta_P = R_2 \Delta Q + R_2 (R_1 C_1 p + 1) F \Delta u_m \tag{7}$$

We denote: $T_1 = C_1 R_1, T_2 = C_2 R_2, T_3 = C_1 R_2$, then

$$T_1 T_2 p^2 \Delta\theta_P + (T_1 + T_2 + T_3) p \Delta\theta_P + \Delta\theta_P = R_2 \Delta Q + R_2 (T_1 p + 1) F \Delta u_m \tag{8}$$

Let's introduce dimensionless quantities:

$$\varphi = \Delta\theta_P / \theta_{P_0}; \quad \mu = \Delta Q / Q_{\max}; \quad f = \Delta u_m / u_{m_0}; \tag{9}$$

where Q_{\max} — maximum heat gain with fully open valve.

Substituting the values of $\Delta\theta_P, \Delta Q$ and Δu_m into equation (8), we obtain

$$T_1 T_2 p^2 \varphi + (T_1 + T_2 + T_3) p \varphi + \varphi = k_0 \mu + k_1 (T_1 p + 1) f, \tag{10}$$

where T_1, T_2, T_3 — time constants:

$$\left. \begin{aligned} T_1 &= C_1 R_1 = \frac{C_1}{\alpha S}, \\ T_2 &= C_2 R_2 = \frac{C_2}{u_{m_0}(c_T + c_P m_2) + (A_1 + A_2)}, \\ T_3 &= C_1 R_2 = \frac{C_1}{u_{m_0}(c_T + c_P m_2) + (A_1 + A_2)}; \end{aligned} \right\} \tag{11}$$

k_0 — coefficient of controlling panel

$$k_0 = \frac{Q_{\max} R_2}{\theta_{P_0}} = \frac{Q_{\max}}{[u_{m_0}(c_T + c_P m_2) + (A_1 + A_2)] \theta_{P_0}}; \tag{12}$$

k_1 — coefficient of transmission to the perturbation channel

$$k_1 = \frac{u_{m_0} [(c_T + c_{P_1} m_1) - (c_T + c_P m_2)] \theta_{T_0}}{u_{m_0}(c_T + c_P m_2) + (A_1 + A_2)} \cdot \theta_{P_0}. \tag{13}$$

Consequently, the dynamic properties of the heated impregnating reservoir correspond to the dynamic properties of the 2nd order link, at the input of which an equivalent disturbance acts $(T_1 p + 1) f$. This link is characterized by three time constants and the transfer coefficient k_0 . Taking into account other perturbations caused by changes in humidity m_1 and m_2 , the temperature of the incoming tissue θ_T and other factors, additional terms would enter the right side of equation (10).

Transfer function in relation to control action

$$W_0(p) = \frac{k_0}{T_1 T_2 p^2 + (T_1 + T_2 + T_3) p + 1}, \tag{14}$$

and with regard to the disturbing effect

$$W_f(p) = \frac{k_1(T_1 p + 1)}{T_1 T_2 p^2 + (T_1 + T_2 + T_3)p + 1} \quad (15)$$

Considering a structural mathematical model of the solution temperature regulation process. Equations (6) and (5) can be seen as

$$\Delta\theta_p = W_1(p)\Delta\theta_{CT} + W_2(p)\Delta u_m \quad (16)$$

$$\Delta\theta_{CT} = W_3(p)\Delta Q + W_4(p)\Delta\theta_p \quad (17)$$

where

$$W_1(p) = [C_2 p + (1/R_1 + 1/R_2)]^{-1} \frac{1}{R_1}; \quad (18)$$

$$W_2(p) = F[C_2 p + (1/R_1 + 1/R_2)]^{-1}; \quad (19)$$

$$W_3(p) = R_1(R_1 C_2 p + 1_2)^{-1}; \quad (20)$$

$$W_4(p) = (R_1 C_2 p + 1_2)^{-1} \quad (21)$$

The system of equations (16) and (17) corresponds to the block diagram in Fig. 1 b, in which there is a loop with positive feedback on the parameter $\Delta\theta_p$. Transfer function in relation to control action ΔQ

$$W_0(p) = \frac{\Delta\theta_p}{\Delta\theta_1} = \frac{W_1(p)W_3(p)}{1 - W_1(p)W_4(p)} \quad (22)$$

After substitution of values $W_1(p)$, $W_3(p)$ and $W_4(p)$ find the value corresponding $W_0(p)$ to its value obtained from equation (14).

Transfer function with respect to disturbance

$$W_f(p) = \frac{\Delta\theta_p}{\Delta u_m} = \frac{W_2(p)}{1 - W_1(p)W_4(p)} \quad (23)$$

Substitution of the values of the transfer functions gives the corresponding value obtained from equation (15).

Example. To estimate the numerical values of the parameters of an object, let us consider as an example an impregnating reservoir with a volume $V = 60l = 0,06m^3$ and $F_{\text{жс}} = 0,5m^2$ surface of liquid evaporation. The fabric enters the reservoir with moisture $m_1 = 0,1$ (10%). The mass of 1 m of air-dry fabric is 0.16 kg, the mass of 1 m of dry fabric is $0,16(1 + m_1) = 0,16(1 + 0,1) \approx 0,145$ kg. The fabric moves at $v = 70m / \text{min} = 1,16m / s$ speed. The specific heat capacity of the solution in the reservoir is close to the specific heat capacity of water - $c \approx 4,19 \text{ kJ} / (\text{kg} \cdot ^\circ\text{C})$. The moisture content of the outlet $m_2 = 1,2$. The loss of heat from the reservoir to the environment by heat transfer due to their small value is neglected and considered $A_1 \approx 0$. In the temperature range of the solution $40 \div 80^\circ\text{C}$ and the parameters of the air above the solution $t_{\text{возд}} = 30^\circ\text{C}$ and $\varphi = 90\%$, it can be assumed that the coefficient is $A_2 = 0,15 * F_{\text{жс}} = 0,15 * 0,5 = 0,075 \text{ kJ} / (\text{c} \cdot ^\circ\text{C})$.

Heat capacity of the reservoir $C_2 = V\rho_p c_p \approx 0,06 * 1000 * 4,19 \approx 251 \text{ kJ} / ^\circ\text{C}$. Mass rate of fabric $u_m = 0,145 * 1,16 = 0.17 \text{ kg} / \text{s}$. Thermal resistance

$$R_2 = \frac{1}{u_{m_0} (c_T + c_p \cdot m_2) + A},$$

$$R_2 = \frac{1}{0,17 \cdot (1,38 + 4,19 \cdot 1,2) + 0,075} = 0,86^\circ\text{C} / \text{kVt}.$$

Time being $T_2 = C_2 R_2 = 251 * 0,86 = 216 \text{ s}$

The heat capacity of the C_1 coil, half filled with condensate, fluctuates usually within 15-20 kJ/°C, and the time constant is 15-40 s, depending on the degree of contamination of the coil surface. Taking the average values, we get $T_1 \approx 25$ s, $T_3 = C_1 R_2 = 18 * 0,86 = 15,5$ s, in case $T_1 + T_2 + T_3 = 25 + 216 + 15,5 = 256$ s.

For a numerical estimate of the transmission coefficient k_0 , it is necessary to have data on the maximum steam inflow into the coil when the control valve is fully opened. Let us assume that at a steam pressure in the steam line $p_{a\delta c} = 0,2$ MPa ($p_{u3\delta} \approx 2$ kgf / sm²), the maximum steam consumption, determined by the thermal resistance of the coil and the temperature difference between the steam and the solution, is $G_{0\max} \approx 90$ kg / h = 0,025 kg / s. Then $Q_{1\max} = G_{0\max} (i_n - i_k) = 0,025 * 2104 = 54$ kJ/s and the transfer coefficient. If we take the nominal temperature of the solution $\theta_{p_0} = 65$ °C, then is $k_0 = 46,5 / 65 = 0,72$. If there is no coil and the reservoir is heated by live steam, thermal resistance $R_1 = 0$, heat capacity $C_1 = 0$ and equation (10) transforms into the equation of the 1st order object:

$$(T_2 p + 1)\varphi = k_0 \mu + k_1 f \quad (24)$$

Conclusion

The presented algorithm for constructing a mathematical model of the bleaching process allows automating the process of forming a dynamic model of the process to assess the dynamic properties of an impregnating reservoir, on the basis of which a highly efficient resource management system and energy-saving technology can be developed.

In the future, in order to create a methodology for creating an automated control system for the bleaching materials, it is advisable to improve the developed algorithm, expand the range of tasks to be solved, as well as develop intelligent control systems in various subject areas.

References:

1. Polyakov, K.A., Polyakov, A.E. (2005). Reshenie zadachi optimizatsii ehnergosberegayushhikh rezhimov tekstil'nogo oborudovaniya [Solving the problem of optimizing energy-saving modes of textile equipment]. *Izv. Vuzov. Tekhnologiya tekstil'noj promyshlennosti*. 1, 124-127.
2. Yusupbekov, N.R., Igamberdiev, KH.Z., Bazarov, M.B. (2008). Modelirovanie i upravlenie proizvodstvenno-tehnologicheskimi sistemami s parametricheskimi neopredelennostyami interval'nogo tipa [Modeling and control of production and technological systems with parametric uncertainties of interval type]. *KHimicheskie tekhnologii. Kontrol' i upravlenie*. 4, 74-78.
3. Belenkij, L.I., Omelyanchuk, L.A., Shvirev, S.S. (1990). *Avtomaticheskoe upravlenie tekhnologicheskimi protsessami otdelochnogo proizvodstva [Automatic control of technological processes of finishing production]*. M.: Legpromizdat. 208 p. (in Russian).
4. Pupkov, K.A. (2000). *Analiz i staticheskaya dinamika sistem avtomaticheskogo upravleniya [Analysis and static dynamics of automatic control systems]*. Moskva: Redaktsiya. MG TU im. N.EH. Bauman. 748 p. (in Russian).
5. Mallaev, A.R., Usmanova, R.S. (2016). Povysheniya nedyozhnosti ustanovki gidroochistki zhidkogo topliva [Increasing the unreliability of the liquid fuel hydrotreating unit]. *"Integratsiya mirovykh nauchnykh protsessov kak osnova obshhestvennogo progressa"*: *Mezhdunarodnyj sbornik nauchnykh trudov*. 33, Kazan, 225-228. (in Russian).
6. Bekkulov, J., Ibragimov, B., Eshonkulov, M. (2021). Mathematical model of the trajectory of moving control objects. *Engineering sciences: problems and solutions*. 110-116.
7. Mallayev, Alisher Rajabaliyevich, Xusanov, Suban Nurillayevich (2019). Estimation of Parameters of Settings of Regulators Based on Active Adaptation Algorithm. *International Journal of Advanced Research in Science, Engineering and Texnology*. 6(8), 10376-10380.
8. Mallaev, A.R., KHusanov, S.N. (2019). Algoritmy sinteza adaptivnogo suboptimal'nogo regulatora dlya stokhasticheskogo obekta upravleniya [Synthesis algorithms for an adaptive suboptimal controller for a stochastic control object]. *Materialy mezhdunarodnoj nauchnoj konferentsii «Innovatsionnyj resheniya inzhenerno-tehnologicheskikh problem sovremennogo proizvodstva»*. Bukhara, 14-16 noyabr 2019. 237-240. (in Russian).
9. Mallaev, A.R., Xusanov, S.N., Sevinov, J.U. (2020). Algorithms of nonparametric synthesis of discrete one-dimensional controllers. *International Journal of Advanced Science and Technology*. 29(5s). 1045-1050.
10. Nigmatova, F.U., Somansurova, M.Sh., Siddiqov, I.Kh., Musakhanov, A.A. (2014). Design technique for organizational process flowsheet in clothing manufacture. *Automation and Remote Control*. 75(6), 1130-1136.

11. Siddikov, Isamiddin Xakimovich, Khujanazarov, Ulugbek Olimovich, Izmaylova, Renata Nikolayevna, Yunusova, Sayyora Tashkenboevna, Alimova, Gulchexra Raximjonovna (2021). Design Of Standard Regulators For Multi-Link Control Objects. *Turkish Journal of Computer and Mathematics Educati*. 12(7), 349-353.
12. Siddikov, I.X., Umrzoqova, D.M. (2019). Synthesis of Adaptive Control Systems of a Multidimensional Discrete Dynamic Object with a Forecasting Models. *International Conference on Information Science and Communications Technologies. Applications, Trends and Opportunities, ICISCT 2019*.
13. Ibragimov, B. SH. Matematicheskaya model' protsessa regulirovki material'nogo balansa pri otbelivanii tkani (na primere vanny s rastvorom) [Mathematical model of the material balance adjustment process during fabric bleaching (on the example of a bath with a solution)]. *Internauka*. 47-50. (in Russian).
14. Sheraliyevich, I.B., Berdimurodovich, E. S. (2021). Basic principles of automation control of heating of protected ground structures. *ResearchJet Journal of Analysis and Inventions*, 2(5), 1-7.
15. Ibragimov, B.SH., EHshkobilov, S.B. (2020). Matematicheskaya model' protsessa proizvodstva para kak ob'ekta upravleniya [Mathematical model of the steam production process as a control object]. *Internauka*. (18-2), 10-13. (in Russian).
16. Bekkulov, ZH.SH., Ibragimov, SH. (2021). Optimal'noe upravlenie periodicheskimi protsessami [Optimum batch control]. *Central Asian Journal of Theoretical and Applied Science*. 2(5), 184-190. (in Russian).