

PAPER • OPEN ACCESS

Layered application of mineral fertilizers with the coulter ripper of a combined unit

To cite this article: Z Batirov *et al* 2021 *IOP Conf. Ser.: Mater. Sci. Eng.* **1030** 012168

View the [article online](#) for updates and enhancements.

You may also like

- [Multi-tier archetypes to characterise British landscapes, farmland and farming practices](#)
Cecily E D Goodwin, Luca Bütikofer, Jack H Hatfield *et al.*
- [Large scale commissioning and operational experience with tier-2 to tier-2 data transfer links in CMS](#)
J Letts and N Magini
- [Analysing the structure of Kazakhstan university undergraduate students' knowledge about the force concept: findings from a three-tier FCI survey](#)
Nursultan Japashov, Bagdat Abdikadyr, Nuri Balta *et al.*



The Electrochemical Society
Advancing solid state & electrochemical science & technology



249th
ECS Meeting
May 24-28, 2026
Seattle, WA, US
Washington State
Convention Center

Spotlight Your Science

**Submission deadline:
December 5, 2025**

SUBMIT YOUR ABSTRACT

Layered application of mineral fertilizers with the coulter ripper of a combined unit

Z Batirov, I Toirov, F Boymuratov and Sh Sharipov

Karshi Engineering Economic Institute, 180100, Karshi, Uzbekistan

E-mail: botirov1972@inbox.ru

Abstract. The applied methods of fertilizing cotton in Uzbekistan have a number of significant disadvantages. They do not provide available nutrients to the plant's root system. With the distribution of fertilizers in the zone of root development in layers in the required ratio, the coefficient of their use and the yield of cotton increases. (Purpose of the study) To substantiate the design parameters of a subsoiler's distribution pipeline for three-tier fertilization. (Materials and methods) The design of a developed pipeline distributor for three-tiered fertilization is presented. The subsoiler is equipped with a fertilizer distribution pipe, which consists of a cylindrical and inclined funnel-shaped part, a high-flow channel and a lower fertilizer distributor. In the conductive channel, two branch pipes with reflective plates are installed, which cut the moving fertilizers and direct them to the appropriate soil horizon. (Results and discussion) We investigated the movement of mineral fertilizer granules along the fertilizer channel, on the basis of which the length of the pipes of the upper and middle tiers was determined.

Experiments were carried out to study the influence of the length of the protruding part of the baffle plates of the branch pipe and the angle of inclination of the pipeline-distributor funnel on the distribution of fertilizers and on the unevenness of the flow of fertilizers into the upper, middle and lower tiers. The parameters of the loading funnel of the vertical pipeline, branch pipes and movable plates of the upper and middle tiers, in addition to the fertilizer diffuser of the lower tier, were substantiated.

We theoretically and experimentally substantiated the parameters of the nozzles of the upper and lower tiers. With optimal lengths of the branch pipe and baffle plates, a given fertilizer placement depth is provided in three tiers with the required amount of fertilizer. The influence of the parameters of the distribution pipeline on the uniformity of fertilizer distribution in the upper, middle and lower tiers was established. The rational parameters of the lower fertilizer spreader were substantiated, which ensures uniform distribution of fertilizers over the working width of the working body.

1. Introduction

Increasing importance is attached to the use of mineral and organic fertilizers in agriculture as the main factor in increasing the productivity of agricultural crops. Science and practice have indisputably proven that fertilizers can more than double the yield [1]. In ensuring high and sustainable crop yields, an important role belongs to mineral fertilizers, the effective and high-quality use of which is the most important factor in obtaining a high yield [1-3]. Currently, in a market economy, it is necessary to ensure the maximum return on each kilogram of fertilizers. However, the currently applied



fertilization system has a number of significant disadvantages. It does not meet the basic principle of agrochemistry of feeding the plants, not the weeds and soil. Due to the shortcomings of the existing equipment and technology of fertilization and the low propagation of agricultural advantages, the coefficient of nitrogen use is only 0.60-0.65, and that of phosphorus is only 0.15-0.20 [1].

One of the reasons for the low efficiency of applied mineral fertilizers, in addition to the other reasons mentioned above, is the shortcomings of the existing technology and technical means for preparing the soil for sowing and local fertilization [1].

With traditional technologies of soil preparation for sowing, the labour productivity decreases, the labour and fund consumption increases, soil compaction occurs, the soil preparation time is delayed, and the soil is intensively dried, which entails a decrease in crop yields. It has been established that more promising technologies are those that prepare the soil for sowing and apply fertilizers in one unit pass [4-11].

The authors previously proposed a new method of cotton cultivation that ensures the maximum use of applied fertilizers [12]. The essence of the proposed method is as follows. In the fall, after harvesting cotton stalks, deep loosening is performed in the locations of sowing rows with simultaneous three-layer fertilization and ridge formation. The existing subsoiler fertilizer is supplied with fertilizer coulters for layer-by-layer fertilization under the formed ridges with a row spacing of 60 or 90 cm. Fertilizer is applied to the top layer to a depth of 16-18 cm with a tape 2.5-3.0 cm wide, the middle layer to a depth of 28-30 cm with a tape 2.5-3.0 cm wide, and the bottom layer to a depth of 40-45 cm with a tape 20-25 cm wide.

2. Method

For three-tier fertilization, we developed a subsoiler pipeline distributor. During operation of the subsoiler, from the dosing device through cylindrical part 1 of the pipeline, mineral fertilizers are transported to inclined funnel-shaped part 2 and proceed down it into conductive channel 3 of the pipeline distributor. When moving along the conductive channel, a certain part of the fertilizer, reflected by plates 6 and 7 along pipes 4 and 5, is directed to the corresponding soil horizons. The rest of the fertilizer with the help of scatterer 8 is evenly distributed over the width of the loosening working body [12, 14].

The tubing of the subsoiler fertilizer must meet the following basic requirements: provide a convenient layout behind the loosening working body of the subsoiler, and ensure a high-quality distribution of mineral fertilizers at specified depths and a minimum pulling resistance. Based on these requirements, the main parameters are substantiated by loading the funnel of the vertical pipeline, the branch pipes and movable plates of the upper and middle tiers, and the fertilizer diffuser of the lower tier of the distribution pipeline.

Theoretical research was carried out using the basic provisions of theoretical mechanics, mathematical analysis and mathematical statistics, and experimental research, using a specially designed stand on a soil canal and using high-speed filming in the field in accordance with regulatory documents for testing agricultural equipment.

The aim of the study is to substantiate the design parameters of the subsoiler's distribution pipeline for three-tiered fertilization. The effect of the pre-sowing methods of superphosphate application on the yield of raw cotton was studied by Ya. I. Chumanov in field experiments. The best embedding of fertilizers was determined to be a two-layer deep placement of phosphorus at depths of 15-16 and 26-27 cm. With this configuration, compared with embedding with a conventional plow, the yield of raw cotton increases by 3.9 centners/ha.

F. I. Reshetnikov studied various methods of adding phosphorus by the method of labelled atoms, in which a radioisotope in the form of P32 was used. Using this method, it was found that with sowing and early fertilization, the required positional availability of phosphorus in fertilizers for young cotton plants was not achieved. The best results were obtained in laboratory experiments when a small amount of phosphorus was applied to horizontal screens to a depth of 10-15 cm from the soil surface.

Under these conditions, the period from germination to the beginning of consumption of the applied phosphorus is 10-15 days, and the proportion of plants consuming phosphorus fertilizers is 78-90%.

According to I.A. Baranov and V.A. Pisemsky, under local methods of applying superphosphate, phosphoric acid is rapidly released from the fertilizer lumps and concentrates around them, forming a saturated region or focus with readily soluble and readily available compounds for plants. Such foci persist for a very long time. In addition, no significant movement of phosphoric acid in the soil was observed. However, with the local method, the concentrated application of fat in one layer can lead to undesirable consequences, as a result of which the finest root hairs of the root system, which are most sensitive to salting, may suffer.

An analysis of the previous research work indicates that in order to increase the availability of nutrients for the root system, it is necessary to distribute them in the sphere of action of the roots in layers. With layer-by-layer application, fertilizers can be distributed in layers in the desired ratio. This is a very important circumstance. It allows one to take into account the peculiarities of the development of the root system of plants, the dynamics of soil moisture and the processes of absorption of nutrients in the soil.

The length of the branch pipes to ensure a tiered arrangement of fertilizers in the soil should be such that the fertilizers of the lower tier have time to be covered with soil to the level of the upper tier. Based on this, we determine the length of the pipes of the upper L_1 and middle L_2 tiers

$$L_1 = \frac{1}{2} V_n t_1 = \frac{1}{2} V_n \sqrt{\frac{2 \cos \varphi_1 (a + \sqrt{a^2 - 2b(h - h_2) \operatorname{tg} \xi_1})}{g \sin \xi_1 \sin(\xi_1 - \varphi_1)}}, \quad (1)$$

$$L_2 = \frac{1}{2} V_n t_2 = \frac{1}{2} V_n \sqrt{\frac{2 \cos \varphi_1 (a + \sqrt{a^2 - 2b(h - h_2) \operatorname{tg} \xi_1})}{g \sin \xi_1 \sin(\xi_1 - \varphi_1)}}, \quad (2)$$

where a is the depth of the loosened soil layer, m;

b - furrow width, m;

h - embedding depth of fertilizers of the lower tier, m;

h_1 - embedding depth of middle layer fertilizers, m;

h_2 - embedding depth of fertilizers of the upper tier, m;

ξ_1 - angle of the natural soil slope, deg;

g - acceleration of gravity, m/s²;

φ_1 - angle of internal soil friction, deg.

An analysis of equations (2) and (3) shows that with an increase in the speed of the unit V_n and an increase in the coefficient of internal friction of the soil, the length of the branch pipe should be increased. With $V_n=0,75 \dots 1,75$ m/s, $b=0,04$ m, $\varphi_1=28-40^\circ$, $h_1=0,28-0,30$ m, and $h_2=0,16-0,18$ m, the length of the branch pipes are $L_1=0,24-0,54$ m and $L_2=0,18-0,43$ m.

3. Results and Discussions

The results of experiments to study the effect of the length of the protruding part l_2 of the reflective plate of the middle tier branch pipe (at $l_1=25$ mm) on the fertilizer distribution are shown in Fig. 1a. Analysis of the research results shows that at all angles of inclination of the nozzle and constant $l_1=25$ cm with a change in the length l_2 of the reflective plate of the middle tier from 25 to 45 mm, the amount of fertilizers entering the middle tier increases, while in the upper tier, it remains approximately constant (approximately 33%). For example, when $\xi = 75^\circ$, the amount of fertilizers in the middle tier increases from 11.1% to 33.5%, and in the lower tier, it decreases from 55.3% to 32%. A similar regularity in the distribution of fertilizers over the layers, depending on the length l_2 of the reflecting plate of the middle tier and the angle ξ of the slope of the branch pipe, is also observed at $l_1=30$ mm (Fig. 1c).

From Fig. 1a and b, it also follows that (at constant values of l_2 and ξ) with an increase in the length l_1 of the reflecting plate of the upper tier increases, the amount of fertilizers distributed in the upper and middle tiers decreases, and in the lower tiers, it remains constant.

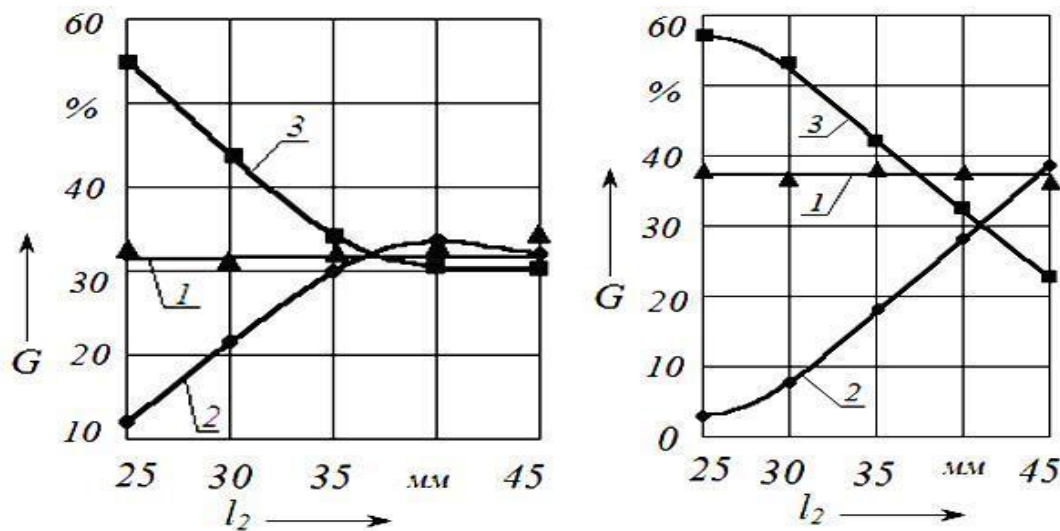

Figure 1. Distribution of fertilizers over the tiers (1 - upper; 2 - middle and 3 - lower) depending on the length l_2 of the protruding part of the middle tier plate: a - at $\xi = 75^\circ$ and $l_1 = 25$ mm; b - $\xi = 65^\circ$ and $l_1 = 30$ mm

The distribution of fertilizers in the tier (1 - upper, 2 - medium and 3 - lower), depending on the length l_2 , the protruding part of the plate of the middle tier: a - for $\xi = 75^\circ$ and $l_1 = 25$ mm; b - $\xi = 65^\circ$ and $l_1 = 30$ mm

It was found that at constant values of the length of the reflective plates, with a decrease in the angle of inclination of the branch pipe, the amount of fertilizers entering the upper tier decreases, and in the lower tier, it increases. This is because with a decrease in the angle of inclination of the nozzle, the area in the conductive channel, covered by the reflective plates, decreases [16,17,25,28].

To study the mutual influence of these factors, as well as to determine their rational values, multifactorial experiments were carried out. The levels of factors varied within the following limits: the angle of inclination of the branch pipe to the vertical ξ varied from 55° to 75° with an interval of 10° , the length l_1 of the reflective plate of the upper tier branch pipe varied from 25 to 35 mm with an interval of 5 mm, and the length of the reflective plate of the middle layer branch pipe l_2 varied from 30 to 40 mm at 5 mm intervals.

To obtain a mathematical model of the distribution of mineral fertilizers in three tiers under the influence of the above factors, the Hartley plan was used (Ha_3). The number of fertilizers (in %) falling into the upper, middle and lower tiers was taken as the response function.

After processing the results of the experiment on a computer, regression equations were obtained that adequately describe the amount of fertilizers in the upper, middle and lower tiers. When solving the obtained regression equations, taking into account the necessary distribution of fertilizers, the following rational parameters were obtained: $l_1 = 26 \dots 30$ mm, $l_2 = 33 \dots 37$ mm and $\xi = 60^\circ$.

The influence of the angle of inclination of the funnel on the distribution of fertilizers over the tiers was studied with the optimal parameters of the reflecting plates, i.e., with $l_1 = 28$ mm, $l_2 = 35$ mm and $\xi = 60^\circ$.

It can be seen from the results (Fig. 3a and b) of the study that the distribution of fertilizers and their uniformity over the tiers, which meet the agrotechnical requirements, are provided at an angle of inclination of the funnel of 55° .

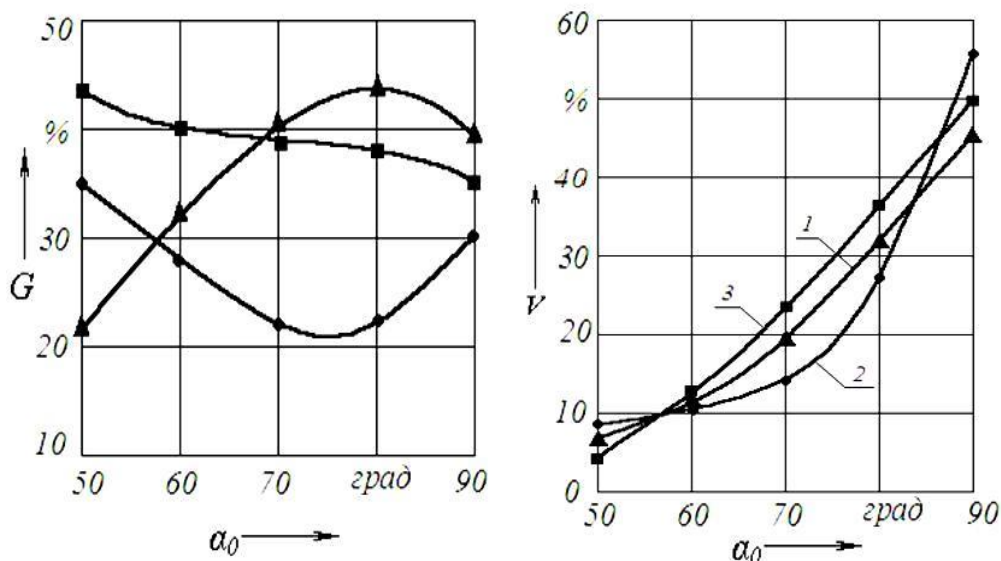

Figure 2. Influence of the angle of inclination of the distributor-distributor funnel on the distribution of fertilizers (a) and on the unevenness of the intake of fertilizers (b) in the upper (1), middle (2) and lower (3) tiers

The lower diffuser (Fig. 3) serves to evenly distribute fertilizers across the width of the working body. For the normal course of the process, the height h_2 of the rear wall of the groove of the middle part and at the edges of h_1 are interconnected by the equality $h_2=5h_1$. Therefore, when choosing the controlled factors affecting the uniformity of the distribution of fertilizers along the width, in addition to α_2 and β_2 , instead of two heights of the rear wall h_1 and h_2 , one height, h_1 , was adopted.

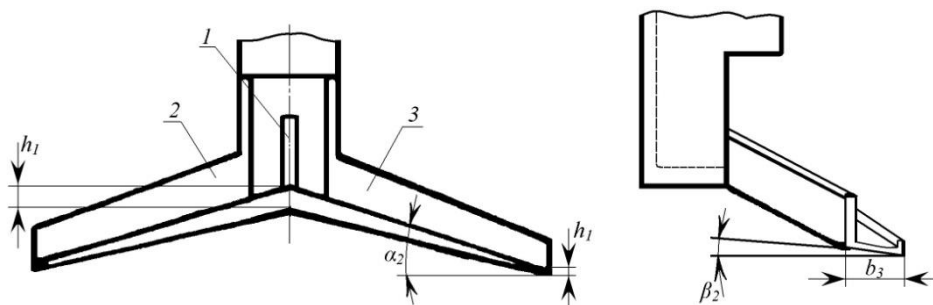

Figure 3. Scheme of the lower distributor of fertilizers: 1-dividing plate, 2, 3-grooved diffuser

Optimization of the parameters of the lower fertilizer spreader was carried out using the method of mathematical planning of the experiment. Here, the levels of factors varied within the following limits: the angle of slope of the grooves in the transverse-vertical plane α_2 varied from 15 to 25° with an interval of 5°, the angle of inclination of the grooves in the longitudinal-vertical plane β_2 varied from 24 to 38° with an interval of 7°, and the height of the rear wall of the groove H_2 varied from 0.5 to 1.5 mm with an interval of 0.5 mm.

Experimental studies were carried out according to the plan of Hartley (Ha_3). After processing the results on the ECM, a regression equation was obtained that adequately describes the uneven distribution of fertilizers along the width of the strip of the lower tier. Analysis of the resulting equation shows that the uniformity of fertilizer distribution over the width of the strip of the lower tier

is most influenced by the height of the rear wall of the groove, an increase in which leads to a more uneven distribution.

Upon solving the obtained equation on a computer by the method of penalty functions SUMT under the condition $Y_4(X)_{min}$ min, the optimal values of the factors were obtained: the angle of inclination of the grooves in the transverse-vertical plane $\alpha_2=17^\circ$; the angle of inclination of the grooves in the longitudinal-vertical plane $\beta_2=29^\circ 9'$; and the height of the rear wall of the groove at the end of the diffuser $h_1=0,5$ mm. Then, the height of the rear wall of the groove along the axis of symmetry is $h_2=2,5$ mm.

The results of experimental studies of the influence of the length of the nozzles L_1 and the middle L_2 of the tiers on the depth of fertilizer placement show that with an increase in the speed of movement, the depth of fertilization in all the layers increases. This is because at higher speed, the soil does not have time to fill up the gap formed behind the rack of the subsoiler working body. In this case, the fertilizer falls to the bottom of the furrow. As a result of the analysis of experimental data, it was found that the optimal length of the upper branch pipe should be 260 mm and that the average length should be 240 mm.

4. Conclusions

The qualitative distribution of mineral fertilizers at the given depths of the fertilizers of the upper and middle tiers constrained the length of their branch pipes to be 260 mm and 240 mm, respectively. The necessary division of fertilizers into three tiers is ensured when the length of the protruding part of the reflective plates of the conductive channel for the upper tier is 26-30 mm and for the middle tier is 33-37 mm. Under these conditions, 40-45% of the fertilizers were distributed to the lower third tier. The rational parameters of the lower fertilizer spreader, which ensures uniform distribution of fertilizers across the working width of the working body, are as follows: the angle of the groove in the longitudinal-vertical plane is $17-19^\circ$, the angle of the groove in the transverse-vertical plane is 29° , the height of the rear edge of the groove in the middle part is 2.5 mm, and the end is 0.5 mm.

References

- [1] Mirzaev B, Mamatov F, Tursunov O. A justification of broach-plow's parameters of the ridge-stepped ploughing <https://doi.org/10.1051/e3sconf/20199705035>
- [2] Batirov Z.L., Shakhobov S.Sh. Machines for applying fertilizers under cotton sowing rows. Karshi: Nasaf, 2008. P-98.
- [3] Lichman G.I., Lichman A.A. Assessment of the impact of the quality of fertilization on the yield of agricultural crops. Agricultural machines and technologies. 2017. N5. P- 16-21.
- [4] Lichman G.I., Kolesnikova V.A., Marchenko N.M., Marchenko A.M. Development of an algorithm for assessing the accuracy of GLONASS / GPS positioning systems for differential fertilization // Agricultural machines and technologies. 2017. N2. P- 4-8.
- [5] Kryazhkov VM, Burchenko PN. The main trends in the development of soil cultivation mechanization // Problems of agricultural mechanization. production. M.: VIM, 1989. N2. P- 6-12.
- [6] Batirov Z.L. Khalilov M.S. Fertilizer coulter of the fertilizer chisel cultivator for applying fertilizers under the cotton sowing rows // International Scientific and Practical Conference "WORLD SCIENCE". 2016. –№ 2 (6), P- 56-59.
- [7] Lobachevsky Ya.P., Mamatov F.M., Ergashev I.T. Front-mounted plow for cotton growing // Cotton. Moscow, 1991. N6. P-35-37.
- [8] Mamatov F.M., Kodirov U.I. Energy-resource machine for preparing soil for planting root crops on ridges // European Science Review. Vienna, 2016. N11. P-125-126.
- [9] Burchenko P.N. Principles of creating combined units for the cultivation of agricultural crops on the basis of passive working organs // Proceedings of the Institute of VIM. Volume 63. Moscow, 1973. P-134-157

- [10] Kashaev B.A., Sizov O.A., Burchenko P.N. The trend of development of technologies and means of mechanization of soil cultivation // Survey information. - M.: VNIITEIagroprom, 1988. P-48.
- [11] Akhmetov A.A., Atakulov Kh.K., Allanazarov M.A., Inoyatov I.A., Nurmihamedov B.U., Uzakbergenov Zh.K. Comprehensive research on the creation of combined tillage machines. Bukhara, 2012. P-154.
- [12] Akhmetov A.A. Soil compacting working bodies of combined tillage machines. Tashkent. Fan. 2013. P-119.
- [13] Khidirov T., Batirov Z.L., Mamatov M.F., Mirzaev B.S., Ruzikulov Z., Yusupov R. UZ No. FAP 00788. Fertilizer coulter. Bulletin of inventions. Tashkent. 2013. N2.
- [14] Mamatov F.M., Batirov Z.L., Xalilov M.C. Chisel-cultivator fertilizer for forming ridges and applying fertilizers// European Sciences review scientific journal. 2018 - №3-4. – P. 267-270.
- [15] Batirov Z.L., Mamatov F.M., Toshtemirov S.J., Xoliyarov Y.B. Energy-resource-saving technology and a machine for preparing soil for planting cotton on the ridges// European Sciences review scientific journal. 2018 - №3-4. – P. 261-264.
- [16] Batirov Z.L., Mamatov F.M., Toshtemirov S.J. Energy-resource-saving technologies and machine for preparing soil for sowing// European Sciences review scientific journal. 2018 - №3-4. – P. 284-287.
- [17] Batirov Z.L., Mamatov M.F. et al. Technology of application of mineral fertilizers to the zone of activity of the root system of cotton // Journal "Young Scientist". - No. 11, Moscow, 2013. - pp. 242–243.
- [18] Mamatov M.F., Batirov Z.L., Khalilov M.S. and others. Traction resistance of a subsoiler with a fertilizer pipe-distributor for three-layer fertilization // Journal "Young Scientist". - No. 11, Moscow, 2013. P- 252–255.
- [19] Mamatov F.M., Batirov Z.L., Khalilov M.S., Kholiyarov J.B. Trekh'yarusnoe vnesenie udobreniy tukoprovodom-raspredelitelem glubokorykhlytelya [Three-tiered fertilizer application with a spreading funnel of a subsoil tiller]. Sel'skokhozyaystvennyye mashiny i tekhnologii. 2019. Vol.13. – № 4. 48-53 (In Russian). DOI 10.22314/2073-7599-2019-13-4-48-53.
- [20] Mamatov F.M., Mirzaev B.S., Avazov I.J. Agrotehnicheskie osnovy sozdaniya protivoroziyionnykh vlagosberegajushhih tekhnicheskikh sredstv obrabotki pochvy v usloviyakh Uzbekistana [Agrotechnical foundations for the creation of anti-erosion water-saving technical equipment for soil cultivation in Uzbekistan]// Prirodoobustroytvo [Environmental Engineering]. Moskva, 2014. – № 4. – P.86-88. [in Russian].
- [21] Abezin V.G. 2004. The mechanization of cultivation of gourds based on resource-saving soil protection technologies Dis Dr tech Sciences (Volgograd) – p 478. [In Russian].
- [22] Barnard R., Luca R., Li J. First-year undergraduate students' perceptions of lecturer and peer feedback: A New Zealand action research project. *Studies In Higher Education*, 2015. 40(5), 933–944.
- [23] Alfred G. J., Brusaw C. T., Oliu W. E. *The business writer's handbook*. New York, 2009.–NY: St Martin's Press.
- [24] Marchenko N.M., Marchenko A.M. Development of an algorithm for assessing the accuracy for differential fertilization // Agricultural machines and technologies. 2017. N2. P- 445-458.
- [25] Izmaylov A.Yu., Lobachevskiy Ya.P. Innovative mechanized technologies and the automated technical systems for agriculture. Modernizatsiya sel'skokhozyaystvennogo proizvodstva na baze innovatsionnykh mashinnykh tekhnologiy i avtomatizirovannykh sistem: Sbornik dokladov XII Mezhdunarodnoy nauchno-prakticheskoy konferentsii. Vol. 1. Moscow: VIM, 2012: 31-44. [In Russian]
- [26] Kolesnikova V.A. Scientific and technical solution of the differentiated application of liquid himization means in system of coordinate agriculture. Avtomatizatsiya i informatsionnoe obespechenie proizvodstvennykh protsessov v sel'skom khozyaystve. Sbornik dokladov XI

- Mezhdunarodnoy nauchno-prakticheskoy konferentsii. Vol. 2. Moscow: VIM, 2010: 638-645. [In Russian]
- [27] Izmaylov A.Yu., Artyushin A.A., Kolesnikova V.A., Lichman G.I., Marchenko N.M., Marchenko A.N., Marchenko L.A., Mochkova T.V., Smirnov I.G. Metodicheskie rekomendatsii po primeneniyu sredstv khimizatsii v sisteme tochnogo zemledeliya [Methodical recommendations about application of means of chemicalization in system of precision agriculture]. Moscow: VIM, 2016: 100. [In Russian]
- [28] Lichman G.I., Marchenko N.M., Kolesnikova V.A., Marchenko A.N. Transient modes of dosing tools in machines for fertilization. *Sel'skokhozyaystvennyye mashiny i tekhnologii*. 2010; 4: 30-33. [In Russian].
- [29] Goswami S.B., Matin S. Aruna Saxena G.D. A Review: The application of Remote Sensing, GIS and GPS in Precision Agriculture *International Journal of Advanced Technology & Engineering Research (IJATER)*. Volume 2, Issue 1, January. 2012 50 pp. 50-54.
- [30] Thomson S. J., Smith L. A., Hanks J. E. AN Instrumentation Platform and GPS Position Latency Issues for Remote Sensing on Agricultural Aircraft. *Transactions of the ASABE* Vol. 50(1): pp. 13-21. 2012.
- [31] Izmaylov A.Yu., Artyushin A.A., Bisenov G.S. Prospects for the use of GLONASS/GPS systems for the transport of agricultural organizations providing . *Sel'skokhozyaystvennyye mashiny i tekhnologii*. 2013; 2: 16-20. [In Russian].
- [32] Nørreemar M., Griepentrog H.W., Nielsen J., Søgaard H.T. The development and assessment of the accuracy of an autonomous GPS-based system for intra-row mechanical weed control in row crops. *Biosystems engineering*. 2008. Vol. 101; 4: 396-410. [In English].